

4160

Programmable Micro-Ohmmeter

Rev. 71.3

Operation Manual



VALHALLA
SCIENTIFIC

VALHALLA SCIENTIFIC INC. CERTIFICATION

Valhalla Scientific, Inc. certifies that this instrument was thoroughly tested and inspected and found to meet published specifications when shipped from the factory. Valhalla Scientific, Inc. further certifies that its calibration measurements are traceable to the National Institute of Standards and Technology to the extent allowed by NIST's calibration facility.

Due to continuing product refinement and due to possible parts manufacturer changes, Valhalla Scientific, Inc. reserves the rights to change any or all specifications without notice.

VALHALLA SCIENTIFIC INC. WARRANTY STATEMENT

The warranty period for this instrument is stated on your invoice and packing list. Please refer to these to determine appropriate warranty dates.

We will repair the instrument during the warranty period provided it is returned to Valhalla Scientific, Inc. freight prepaid. No other warranty is expressed or implied.

Valhalla Scientific, Inc. is not liable for consequential damages.

Permission and a Return Material Authorization number (RMA) must be obtained directly from the factory for warranty repairs. No liability will be accepted if returned without such permission.

SUPPORT

For repair and calibration services, call 800-548-9806 or visit valhallascientific.com.

Email support available at support@valhallascientific.com



4160 Programmable Digital micro-Ohmmeter User Manual
Revision 71-3 (2026)
Copyright © 2026 Valhalla Scientific, Inc. All rights reserved

WARNINGS

The following general safety precautions must be observed during all phases of operation, service, and repair of this product. Failure to comply with these precautions or with specific warnings elsewhere in this manual violates safety standards of design, manufacture, and intended use of the product. Valhalla Scientific assumes no liability for the customer's failure to comply with these requirements.

Ground the equipment: For Safety class 1 equipment (equipment having a protective earth terminal), an interrupted safety earth ground must be provided from the main power source to the product input wiring terminals or supplied power cable.

For continued protection, replace the line fuse(s) only with fuse(s) of the same voltage and current rating and type. DO NOT use repaired fuses or short-circuited fuse holders.

Keep away from live circuits: Operating personnel must not remove equipment covers or shields. Procedures involving the removal of covers or shields are for the use of service-trained personnel only. Under certain conditions, dangerous voltage may exist even with the equipment switched off. To avoid dangerous electrical shock, DO NOT perform procedures involving cover or shield removal unless you are qualified to do so.

DO NOT operate damaged equipment: Whenever it is possible that the safety protection features built into this product have been impaired, either through physical damage, excessive moisture, or any other reason, REMOVE POWER and do not use the product until safe operation can be verified by service-trained personnel. If necessary, return the product to Valhalla Scientific for service and repair to ensure that safety features are maintained.

DO NOT service or adjust alone: Do not attempt internal service or adjustment unless another person, capable of rendering first aid and resuscitation, is present.

DO NOT substitute parts or modify equipment: Because of the danger of introducing additional hazards, do not install substitute parts or perform any unauthorized modification to the product. Return the product to Valhalla Scientific for service and repair to ensure that safety features are maintained.

Measuring high voltage is always hazardous: ALL multimeters input terminals (both front and rear) must be considered hazardous whenever inputs greater than 42V (dc or peak) are connected to ANY input terminal.

Permanent wiring of hazardous voltage or sources capable of delivering greater than 150VA should be labeled, fused, or in some other way protected against accidental bridging or equipment failure.

DO NOT leave measurement terminals energized when not in use.

1. Table of Contents

1. Table of Contents	3
2. General Information	6
Instrument Description	6
Instrument Identification	6
Safety Precautions	6
3. Unpacking and Installing	7
Inspection	7
Setting the Line Voltage	7
Fuse Selection	7
Bench Use	8
Rack Mounting	8
4. Specifications	9
Standard Measurement Mode Specifications	9
General Specifications	10
Environmental	10
Power Requirements	10
Physical	10
5. Getting Started	11
Introduction	11
Front Panel Overview	11
Power Switch	11
Display	12
Range Selection Keys	12
Function/Numerical Keys	13
Source and Sense Binding Posts	13
Rear Panel	14
Line Voltage Switch	14
Fuse Holder	14
Power Connector	14
RS-232 Connector	14
USB Interface	14
Ethernet Port (Optional)	15

Applying Power	16
Power-On Settings	16
Connecting a Load to the 4160	16
Range Selection.....	18
Overload.....	18
6. Measurement Modes and Functions	19
Measurement Mode	19
Display Brightness and Screen Saver Mode.....	20
Run / Hold Feature.....	20
PeakHi/PeakLo Function	20
Send Function	21
LOG Function.....	21
7. Optional Features and Accessories	22
Options.....	22
Ethernet Interface.....	22
Accessories.....	22
Option RX-i: Rack Mount Adapter.....	22
Test Leads	23
Alligator Clip Type Leads	23
Needle Type Probes	23
Surface Probes	24
Other Lead Sets.....	24
8. Remote Interface	25
RS-232 Interface.....	25
USB Interface	26
Ethernet Interface (Optional)	27
Commands	29
Alphabetical Commands & Queries Summary Table	30
System Commands and Queries	31
Measurement Commands and Queries.....	35
9. General Maintenance and Calibration.....	38
General.....	38
Calibration Procedure	39

Sense Calibration	39
Source Calibration.....	40
Special Procedures.....	41
Noisy Readings	41
Inductive Loads	41

2. General Information

Instrument Description

Welcome to the world of low resistance measurement! The precision instrument you have purchased offers exceptionally stable measurement capabilities for challenging items such as transformers, coils, shunts, and even the resistance of wire itself. Additional features include remote interface options.

Please read this manual thoroughly, along with all accompanying addendums, before attempting to operate the ohmmeter.

Instrument Identification

Valhalla Scientific instruments are identified by a two-part serial number located on the Serial Tag, found on the rear or bottom of the device.

The serial number is formatted as **71-XXXXXX**,

where:

The first two digits (the serial number prefix) indicate the model and change only when modifications are made to the instrument.

The last six digits (the serial number suffix) are unique to each individual unit.

Be sure to include the entire serial number—both prefix and suffix—in any correspondence regarding your instrument.

Safety Precautions

The power plug must be a three-contact device and should only be inserted into a matching socket that provides a proper ground connection via the third contact. When using an extension cord, ensure that the ground connection remains continuous; any break in the ground lead could render the unit unsafe.

Testing inductive loads, such as transformers, requires special precautions to prevent damage to the instrument and avoid injury to the operator. For detailed safety procedures, please refer to Chapter 9.

3. Unpacking and Installing

Inspection

If the shipping carton is damaged, request that the carrier's agent be present during unpacking. If the instrument appears damaged, the carrier's agent should approve any repairs before the unit is returned to the factory. Even if the instrument looks undamaged externally, internal damage may have occurred during transit and might not be visible until the unit is operated or tested to verify compliance with its specifications.

If the unit fails to operate or does not meet the specified performance standards, notify both the carrier's agent and the nearest Valhalla Sales Office. Retain the original shipping carton for carrier inspection.

Important: Do not return the equipment to Valhalla Scientific, Inc., or any of its sales offices without prior authorization.

Setting the Line Voltage

The line voltage selection is preconfigured based on the destination country or as specified by the customer.

To change this setting:

1. Disconnect the power cord from the instrument.
2. Using a small flat-head screwdriver, slide the **“Line Voltage Selector”** switch to the appropriate position.
3. Replace the line fuse accordingly.

Fuse Selection

Before operation, verify the following:

- The instrument is set for the correct local AC line voltage, selected via the rear panel switch:
115V - 105 Vac to 125 Vac
230V - 210 Vac to 250 Vac
- The proper fuse is installed:
115 Vac: 0.5 Amp Slo-Blo fuse
230 Vac: 0.25 Amp Slo-Blo fuse

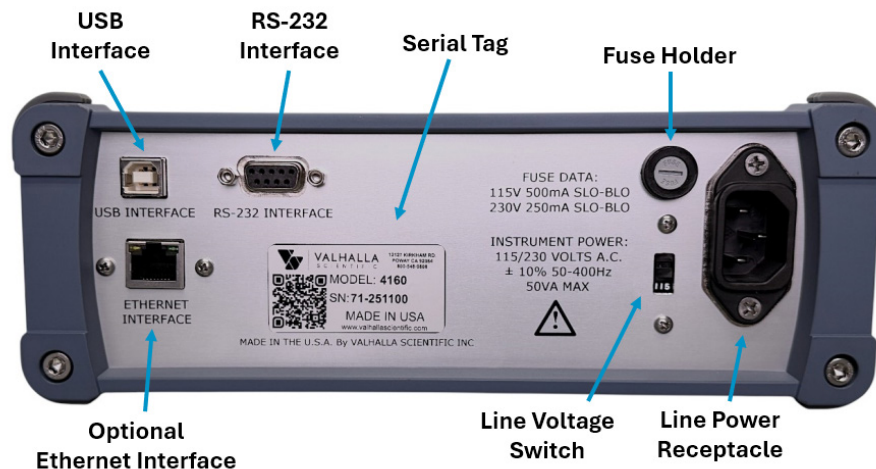

Bench Use

The ohmmeter is supplied with all necessary hardware for bench use. No special instructions are required for standard bench operation. However, it is recommended that users familiarize themselves with Chapter 5 before operating the instrument.

Rack Mounting

Optional brackets are available for mounting the ohmmeter in a standard 19" equipment rack. The rack mount kit (model I-Series Rack Mount) which can be easily installed on the front of the 4160 (see Figure 1).

To promote proper airflow and prevent overheating, install blank panels at least 1.75 inches high between this unit and adjacent rack-mounted devices. Under no circumstances should the ambient temperature around the unit exceed **50°C** during operation or **70°C** when powered off.



Figure 1 - Rack Mount Adaptor RX-i

4. Specifications

The specifications for the 4160 Programmable μ -Ohmmeter are detailed in the following sections. All specifications are valid for full Kelvin Four-Terminal measurements using connections with less than 20m Ω of lead resistance per wire.

Standard Measurement Mode Specifications

#	Range	Test Voltage	Full Scale	Resolution	Current Source ¹	Accuracy ² \pm (% of Reading + Ω)	Temperature Coefficient ³
1	200m Ω	200mV	200.00m Ω	10 $\mu\Omega$	1A	\pm (0.02% + 0.04m Ω)	\pm 20ppm/ $^{\circ}$ C
2	2 Ω	200mV	2.0000 Ω	100 $\mu\Omega$	100mA	\pm (0.02% + 0.0004 Ω)	\pm 20ppm/ $^{\circ}$ C
3	20 Ω	200mV	20.000 Ω	1m Ω	10mA	\pm (0.02% + 0.004 Ω)	\pm 20ppm/ $^{\circ}$ C
4	200 Ω	200mV	200.00 Ω	10m Ω	1mA	\pm (0.02% + 0.04 Ω)	\pm 20ppm/ $^{\circ}$ C
5	2k Ω	200mV	2.0000k Ω	100m Ω	100 μ A	\pm (0.02% + 0.0004k Ω)	\pm 20ppm/ $^{\circ}$ C
6	20k Ω	200mV	20.000k Ω	1 Ω	10 μ A	\pm (0.02% + 0.004k Ω)	\pm 20ppm/ $^{\circ}$ C

Table 1 - Ranges Parameters and Accuracies

¹ Current Source is \pm 1% absolute accuracy.

² The accuracy specifications listed are valid following a 30-minute warm-up at an ambient temperature between 15 $^{\circ}$ C and 35 $^{\circ}$ C and include the effects of line voltage variations within the allowed range.

³ Temperature Coefficient specified for temperature ranges from 5 $^{\circ}$ C to 21 $^{\circ}$ C and 29 $^{\circ}$ C to 50 $^{\circ}$ C.

General Specifications

Display:.....5 Digit / Multi Section OLED Display

Overload Limit:

200mΩ through 20kΩ Range: 149.995 % of Range

Overload Indication:Displays O.L.

Terminal Configuration:.....Four-wire Kelvin

ADC Conversion Rate:100msec

Display Update:.....100msec

Compliance Voltage: 5 VDC nominal

Settling Time 300mSec

Environmental

Operating Temperature Range: 0 to 50°C

Storage Temperature Range:.....-40°C to 85°C

Humidity:..... 80% RH at 40°C non-condensing

Power Requirements

Power Supply Voltage:.....105-125 or 210-250 VAC

Power Supply Frequency: 50 - 60 Hz Power

Supply Consumption:..... 25VA Maximum

Physical

Dimensions:.....9.75"(24.8cm) W x 11.5"(29.2cm) D x 3.5"(8.9cm) H

Weight:.....2.8Kg (6.2 lbs.) Net

5. Getting Started

Introduction

This chapter provides an overview of the fundamental operation of the ohmmeter. It details how to utilize both the front and rear panels, establish proper connections, and interpret the display sections and messages. Before proceeding with measurements, it is helpful to familiarize yourself with each section of the 4160's front and rear panels.

Front Panel Overview

The front panel of the 4160 is divided into four distinct sections. Refer to Figure 2 for a visual layout, with each area labeled accordingly.

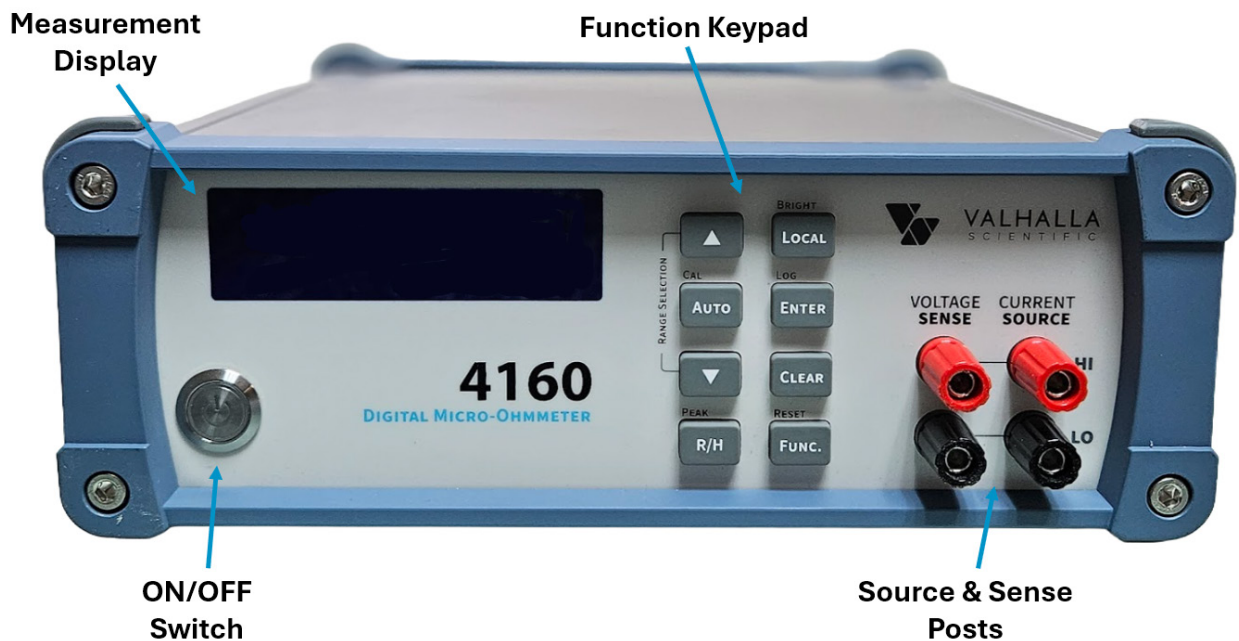

Figure 2 - 4160 Front Panel

Power Switch

The power switch is a two-position push button switch the standard Power Icon. It controls the application of AC power to the ohmmeter's internal circuitry—The switch power icon will illuminate when the switch is in the ON position.



Display

During measurements, the display features four distinct sections, each serving a specific purpose:

Measurement Section

Range Section



Figure 3 - Display Layout

Measurement Section

This section displays the measured value of the load.

Range Section

This section displays range related information. Primarily, the selected range. Other callouts are:

- **AUTO** indicates that the device is in auto range.
- **SAFE** indicates that range 0 has been selected via serial command. Test Current is disabled.

Run Hold Section

This section shows **HOLD** when the hold function is triggered. Blank indicates that the device is in Run mode.

The display also functions as a prompt system, providing alerts and messages to guide the user.

Range Selection Keys

To manually select a measurement range, simply use the UP/DOWN keys.

For Auto Range, press the AUTO key.

CAUTION:

Extra care should be taken when working with inductive loads. Always select the highest resistance range before connecting or disconnecting the test leads to prevent damage or inaccurate readings.



Function/Numerical Keys

There are eight Function keys used to trigger the standard and/or optional ohmmeter functions. Table 2 lists a brief description of each key and its uses. The Function keys will be further described throughout this manual.

Key	Idle State	Function Menu	Additional Function
△	Range Up	View Ethernet/IP info	Navigation
AUTO RNG	Toggle auto-range	CAL - Internal Calibration (guided steps)	
▽	Range Down		Navigation
R/H	Toggles Run/Hold	PEAK - Toggle Peak Hi/Lo	
LOCAL	Exits Remote Mode	BRIGHT - Enter Brightness Configuration	
ENTER	Send/Print current reading via interface	LOG - Toggle logging via interface	Confirmation Key
CLEAR	Return to Idle	Return to Idle	
FUNC.	Enter Function Menu	RESET - Soft reset device	

Table 2 - Key Summary Table

Source and Sense Binding Posts

Connections to the 4160 are made through the front panel source/sense terminals. These consist of two red and two black binding posts, each with gold-plated brass contacts. The posts accept standard banana plugs, wires up to 12 AWG, or spade lugs.

The four terminals support **full 4-wire Kelvin measurement**:

- The **right posts** are the positive and negative current source terminals, supplying the test current.
- The **left posts** are the positive and negative voltage sense terminals, used to monitor the voltage drop across the load.

This 4-wire configuration eliminates measurement errors caused by lead and contact resistances. In many cases, contact resistance can be significantly higher than the load resistance. The 4160 minimizes this error by providing separate current source and voltage sensing terminals, ensuring fast and accurate resistance measurements independent of lead, wire, or contact resistance.

Chapter 6 of this manual will further explain how the 4-wire measurement principle is used to eliminate potential errors from lead and contact resistances.

Rear Panel

The rear panel of the 4160 may vary depending on the optional features installed. This section describes the standard model without any additional options or modifications. If your unit features terminals or connectors not covered here, please refer to any applicable addendum specific to your model.

Line Voltage Switch

The line voltage switch allows you to select the appropriate power setting based on your local AC mains voltage.

- Sliding the switch upward displays "115" and configures the instrument for **115VAC ± 10%**.
- Sliding the switch downward displays "230" and configures the instrument for **230VAC ± 10%**.

Before powering on the ohmmeter, verify that the switch is set correctly for your local line voltage.

WARNING:

Using the incorrect line voltage setting can cause damage to the instrument!

Fuse Holder

The fuse holder on the rear panel provides access to the main power fuse. The fuse values are specified as follows:

- **115 VAC:** 0.5 Amp Slow-Blow Fuse
- **230 VAC:** 0.25 Amp Slow-Blow Fuse

WARNING:

Always replace blown fuses with an exact equivalent to ensure safe and proper operation.

Power Connector

The 3-prong power connector on the rear panel is used to supply AC power to the instrument. The included power cord mates with this connector.

RS-232 Connector

The RS-232 serial interface is accessible via the 9-pin female D-Sub connector located on the rear panel. For certain applications, understanding the specific pin functions may be necessary; refer to **Chapter 8: Remote Interface** for detailed pin assignments.

USB Interface

This interface allows for easy data transfer, configuration, and control of the instrument via standard USB connections.

The USB port supports plug-and-play functionality and is compatible with most modern operating systems. For proper operation, use a standard USB Type B cable to connect the instrument to your computer's USB port.

Refer to **Chapter 8: Remote Interface** for detailed instructions on establishing a connection and configuring communication settings.

Ethernet Port (Optional)

The 4160 may be equipped with an optional Ethernet port located on the rear panel to enable network connectivity. This port allows the instrument to be integrated into local networks for remote monitoring, data logging, or control via standard Ethernet protocols.

The Ethernet port supports standard RJ45 connectors and complies with typical network configurations. To establish a connection, use an appropriate Ethernet cable to connect the instrument to your local area network (LAN).

For detailed setup instructions, including IP address configuration, network settings, and communication protocols, refer to **Chapter 8: Remote Interface** or the network configuration guide provided with your instrument. Proper setup ensures reliable communication and seamless integration into your existing network infrastructure.

Applying Power

Before powering on the instrument, please review safety and setup instructions.

To turn on the ohmmeter, set the front panel power switch to the **ON** position. If the device does not power up, verify that it is properly connected to the power line. If power connection is confirmed but the instrument still does not start, check the line power fuse and ensure that the line voltage selection switch is set correctly for your local voltage.

Power-On Settings

When the ohmmeter is powered on, it initializes with the following factory default settings:

Function	Default Setting
Range	20 k Ω
Auto-Range	ON

Connecting a Load to the 4160

The first step in using the ohmmeter is to connect it to the load or device under test. Valhalla Scientific, Inc. offers a variety of test leads compatible with the Model 4160 and other Valhalla ohmmeters. Refer to **Chapter 7** for a list of available test leads.

All ohmmeter test leads consist of a pair of conductors terminated with multi-stacking dual banana plugs. It is essential to observe the position of the ground marker on each plug to ensure proper connection. The marked side of each banana jack should be connected to the respective **Source** terminals.

Connecting the Leads:

- **Lead 1:** Connect between **SENSE HI** and **SOURCE HI**, with the ground marker on the source side.
- **Lead 2:** Connect between **SENSE LO** and **SOURCE LO**, with the ground marker on the source side.

This configuration ensures that the current source is carried through the largest conductor in the cable, and the sense input remains shielded from interference.

The opposite ends of the leads may have different types of terminations. On the following page, a description of the three most common termination styles will be provided.

Common Termination Styles for Test Leads

The most common termination is alligator clip connectors. If you choose this type of lead, simply attach one clip to one side of your load and the other clip to the opposite side.

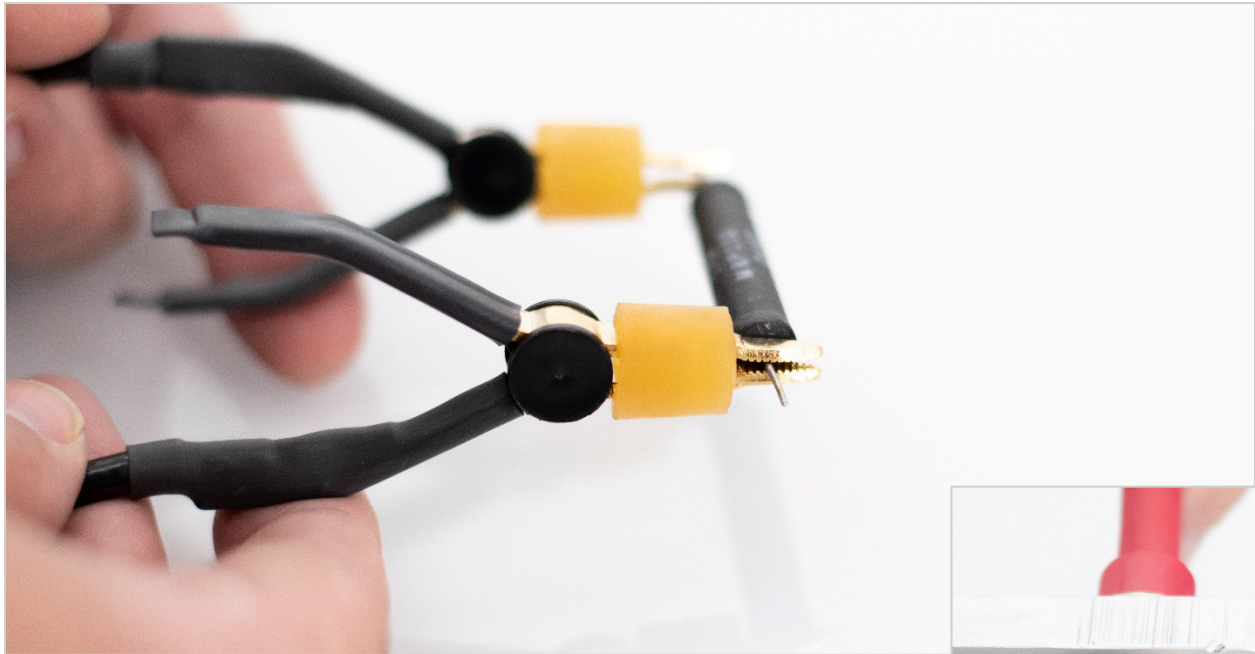

Surface Probes

For measurements on flat surfaces, Valhalla Scientific offers two types of spring-loaded surface probes. To use these:

- Press one probe firmly against one side of the surface of your load, ensuring full contact between the probe surface and the load surface.
- Press the second probe against the opposite side of the load, again ensuring full contact.



Needle Probes

For hard-to-reach surfaces, Valhalla Scientific provides two sets of spring-loaded dual needle probes. These differ in overall size and the distance between the needles. To use them:

- Press both needles of one probe against one end of the load's surface.
- Press both needles of the second probe against the opposite end of the load's surface.

Note:

For a complete list of available lead sets and accessories for the 4160, see **Chapter 7**.

Range Selection

By default, the 4160 is to start in **Auto-Range** mode. In this mode, the display's range window shows **"AUTO"**, and the instrument automatically selects the range that provides the highest resolution for the measured resistance.

In applications where the test current is critical, it may be beneficial to manually select a specific range. You can do this by pressing the appropriate up/down range key. The chosen range will be displayed in the range window.

To switch back to **Auto-Range** mode at any time, press the **"AUTO RNG"** key on the front panel.

Overload

If the load value exceeds the selected range limit, the instrument enters an **Overload** state. During overload, the display will repeatedly flash the word **"OVERLOAD"**. In this case, you should:

- Select a higher range, or
- Press the **Auto** key to allow the instrument to automatically select an appropriate range.

If the load value exceeds the limit of the highest range, promptly disconnect the load from the instrument to avoid damage to the equipment.

Important Note:

If no load is connected to the 4160, the display may also read **"OVERLOAD"**. This is normal and does not indicate a fault with the device. It simply means that there is no load present.

6. Measurement Modes and Functions

The primary feature of the 4160 is its capability to perform **4-wire resistance measurements**.

Measurement Mode

The 4160 powers on in **Standard Measurement Mode**, which measures the load value using a 4-wire configuration. This setup effectively eliminates errors caused by test lead and contact resistance, which in many applications can be several orders of magnitude greater than the load resistance.

The 4-wire measurement technique involves:

- **Two terminals** dedicated to a **constant current source** (positive and negative).
- **Two additional terminals** for **high-impedance voltage sensing**.

This configuration ensures that the measurement is unaffected by lead, wire, or contact resistances, providing a fast and highly accurate resistance reading.

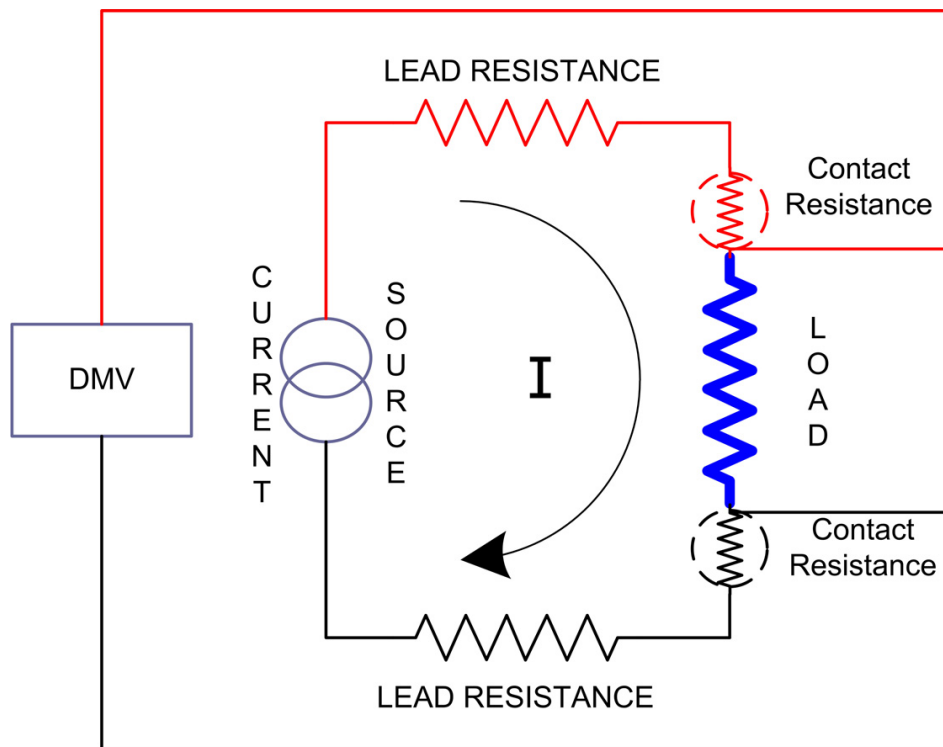

The illustration above demonstrates how the 4-wire method minimizes errors from lead, wire, and contact resistances. The internal current source delivers a precise, constant current that overcomes series resistance within compliance voltage limits. The high-impedance voltage measurement input of the digital voltmeter (DVM) senses the voltage drop across the load, with negligible error introduced by contact or lead resistance due to its high input impedance.

Display Brightness and Screen Saver Mode

The 4160 allows the user to customize the display brightness and activate a screen saver to extend the life of the display.

After **60 seconds** of no user interaction following a keypress, the instrument will automatically enter **screen saver mode**. During this mode, the display will **dim** or **turn off completely** until the next user input.

Brightness Settings:

The display brightness can be set to the following levels:

- **100%** (no dimming)
- **75%** (default setting)
- **50%**
- **25%**
- **0%** (screen turns off)

To set the brightness level press **Func.** then press the **Bright** key. Use the up/down arrow keys to select your preferred brightness level.

```
Brightness Setting
[ ]100%  [*]75%  [ ]50%
[ ]25%   [ ]OFF
```

Other brightness percentages can also be configured via **serial interface commands** for advanced customization.

Run / Hold Feature

The **Run/Hold [R/H]** key toggles the measurement display between **updating** continuously and **holding** the current reading.

- When in **Run mode**, the display updates automatically with new measurements.
- When **Hold mode** is activated, the current reading is **frozen** and will not update until the key is pressed again.

This feature allows the user to capture and record a specific measurement without it changing.

PeakHi/PeakLo Function

The PeakHi/PeakLo function allows the user to see the current reading alongside the maximum and minimum readings recorded while the function is on. This feature helps monitor how the resistance values change over time.

To activate the Peak function, press the **Func.** then **Peak** button on the front panel. Press **Clear** to return to standard mode.

When the Peak function is active, an indicator will show the display of the Peak Hi and Peak Lo values with the current measurement.

```
PkHi 100.75k      200k
RUN  100.20k
PkLo 100.07k
```

Additionally, a beeper will sound each time a new Peak Hi or Peak Lo is measured, providing an audible indication of the new peak values.

Note that enabling the Peak Hi and Peak Lo functions disables the auto range feature, ensuring stable and consistent measurement settings during use.

Send Function

The **Send** function allows the user to transmit a single measurement directly through one of the instrument's serial interfaces—**RS-232**, **USB**, or **Ethernet**—by simply pressing the **Enter** key on the front panel.

The measurement is formatted in ohms with the appropriate multiplier (e.g., 1.23k Ω).

LOG Function

The **LOG** function enables continuous transmission of measurement data via one of the serial interfaces—**RS-232**, **USB**, or **Ethernet**. When activated, the instrument will **send ongoing measurement data** until the user presses the **Func.** then **Log** key again to stop.

To start or stop logging:

- Press the **Func.** then **Log** key on the front panel.

This feature is ideal for real-time data recording, remote monitoring, or trend analysis over extended periods.

The measurement value formatted in ohms with the appropriate multiplier (e.g., 1.23k Ω).

7. Optional Features and Accessories

The 4160 Micro-Ohmmeter are shipped with a detachable power cord as standard equipment. This section lists several items that may be desirable for special applications.

Options

Ethernet Interface

The 4160 may be equipped with an optional Ethernet port located on the rear panel to enable network connectivity. This port allows the instrument to be integrated into local networks for remote monitoring, data logging, or control via standard Ethernet protocols. Details are available in the Remote Interface Chapter of this Manual.

Accessories

Option RX-i: Rack Mount Adapter

The 4160 Micro-Ohmmeter may be mounted in a standard 19" equipment rack using the optional rackmount front panel.



Test Leads

This section details the different test lead sets and connectors available for use with the 4160 Micro-Ohmmeter. All cables and test leads are manufactured by Valhalla Scientific Inc. and tested before shipping.

Alligator Clip Type Leads

K: Kelvin Lead Set

"K" is a shielded, 4-wire Kelvin cable set, 48 inches in length terminated in gold plated alligator clips (*KCS*).

Option "K" is the recommended general purpose lead set for most applications. *Figure 4*.



Figure 4 - K: Kelvin 4-Wire Lead Set

KCS: Gold-Plated Clips

"KCS" are gold-plated alligator clips used on the "K" lead set for 4-wire measurements of smaller components and leads. Clips open to 1/2 inch and accommodate test currents of up to 10A.

C: Banana-to-Clip Cable

"C" is a 48" general purpose shielded lead set terminated on one end in dual banana plugs and on the other end in red and black alligator clips.

KK: Heavy-Duty Lead Set

"KK" is a 4-wire Kelvin cable set, 48-inches in length terminated in heavy-duty gold-plated clamps. *Figure 5*.



Figure 5 - KK: Kelvin 4-Wire Lead Set

JAWS: Gold-Plated Clamps

"JAWS" are gold-plated heavy-duty clamps. Clamps open 2 inches for connection to large motors, bushings, etc.

Needle Type Probes

MP-1: Kelvin Micro-Probes

"MP-1" is a 48-inch shielded 4-wire Kelvin cable set with a 1A test current capacity employing a set of Kelvin Micro-Probes. The probes are equipped with spring-loaded stainless-steel tips with 0.05" spacing.

MP-2: Kelvin Mini-Probes

"MP-2" is a 48-inch shielded 4-wire Kelvin cable set with a 1A test current capacity employing a set of Kelvin Mini-Probes. The probes are equipped with spring-loaded stainless-steel tips with 0.18" spacing.

MP-S: Single Pointed Probe Set

"MP-S" is a 48-inch shielded cable set with a 1A test current capacity employing a set of single pointed handheld pencil type probes. (2 wires to each point).

Surface Probes

MP-4: Surface Probes

These probes permit rapid, repeatable bonding testing on a variety of screened or flat surfaces. Test current is evenly distributed through the probe base while sensing is accomplished via a spring-loaded center contact. The target area is 1-inch in diameter. *Fig. 6*



Figure 6 - MP-4 Surface Probe

MP-5: Surface Probes

These probes permit rapid, repeatable bonding testing on a variety of screened or flat surfaces. Test current is evenly distributed through the probe base while sensing is accomplished via a spring-loaded center contact. The target area is 1/2 inch in diameter.

Other Lead Sets

BBL: Banana-to-Banana Cable

"BBL" is a 48" shielded cable terminated on both ends in dual stacking banana plugs. This cable may be used for voltage and current connections to the ohmmeter.

SL-48: Low Thermal Leads

"SL-48" is a 48" shielded lead set terminated in gold-plated spade lugs. This lead set is designed to eliminate problems caused by thermal EMF's and is rated for the maximum output current of 1A.

8. Remote Interface

This chapter describes how to operate the 4160 remotely via its serial interfaces, including RS-232, USB, and Ethernet. Remote operation enables integration with external systems for automated control, data logging, and monitoring.

RS-232 Interface

Capabilities

The RS-232 interface provides a point-to-point connection between the 4160 and an external device such as a computer. Once configured, you can control the instrument and retrieve data through this interface.

Communication Parameters

Set the RS-232 parameters on both the 4160 and the external device to ensure proper communication:

- **Baud rate:** 115200 baud
- **Parity:** None
- **Data bits:** 8 bits
- **Stop bits:** 1 stop bit
- **Flow control:** None

Notes for Installation

- The 4160 uses a **9-pin D-type female connector** on the rear panel (see Table 3 below for pin assignments).
- Many devices require a constant high signal (e.g., RTS or DTR) on certain input pins.
- Connect the **signal ground** of the external device to the 4160's signal ground.
- Connect the **chassis ground** of both devices.
- Use cables no longer than **15 meters** to prevent signal degradation.
- Ensure that the baud rate and other parameters match between the device and the PC.

	Pin #	Pin Function
	1, 4, 6, 7, 8, 9	Not Connected
	2	Receive Data (RxD) (input)
	3	Transmit Data (TxD) (output)
	5	Signal Ground (GND)

Table 3 - RS-232 Connector Pin Configuration

Connecting to a Computer

1. Connect one end of an RS-232 cable to the computer's serial port.
2. Connect the other end to the 4160's RS-232 port.
3. Power on the 4160.
4. Power on the computer.

Input and Output Queues

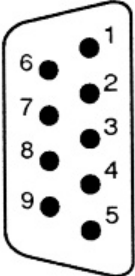
The RS-232 interface uses:

- **Input queue:** 64 bytes
- **Output queue:** 128 bytes

USB Interface

The 4160 is equipped with a standard USB Type B receptacle located on the rear panel. This interface allows for easy connection to a computer for control and data transfer.

Compatibility and Commands

The USB interface supports the same command set as the RS-232 interface. All commands, query formats, and syntax are identical, making the transition between interfaces seamless.

Connection and Setup

1. Connect a USB Type B cable from the 4160 to the computer's USB port.
2. Power on the 4160; the device will be recognized as a COM port by most operating systems.
3. Use your terminal or control software to communicate with the instrument via the assigned COM port.

Software Drivers

Ensure that the appropriate drivers are installed if required. The command set remains the same as outlined for RS-232, simplifying software development and integration.

Ethernet Interface (Optional)

The 4160 can be optionally equipped with an **Ethernet** interface, enabling remote control and data transfer over a local network or the internet. This provides greater flexibility for automation, remote monitoring, and integration into larger systems.

Overview

The Ethernet interface supports standard TCP/IP communication protocols and is configured via the instrument's network settings. Once connected, the 4160 can be controlled using the same command set as the RS-232 and USB interfaces, ensuring seamless integration.

Hardware Connection

1. Connect an Ethernet cable from the 4176's Ethernet port (RJ45 connector) to your network switch, router, or PC directly (using a crossover cable if required).
2. Power on the 4160.

Default Configuration

By default, the Ethernet interface is configured for **Static IP operation** with the following settings:

- **IP Address:** 192.168.1.50
- **Mode:** Static IP

Changing Network Configuration

All Ethernet configuration changes are performed via the **serial or USB interface**.

Set Configuration Mode

- Enable DHCP:
eth dhcp
- Set Static IP mode:
eth stat

Set IP Address (Static Mode Only)

```
eth stat <ip_address>
```

Example: eth stat 192.168.1.100

Set Subnet Mask

```
eth mask <subnet_mask>
```

Example: eth mask 255.255.255.0

Set Gateway

```
eth gw <gateway>
```

Example: eth gw 192.168.1.1

Obtaining the IP Address

To view the IP address and Port setting on the 4160, Press **Func.** followed by the **UP Arrow** Key. The screen will display the following:

A blue rounded rectangular box containing white text. The text is arranged as follows: 'Ethernet Settings' on the first line, 'IP: ###.###.###.###' on the second line, and 'Port: 4160' on the third line.

```
Ethernet Settings
IP:  ###.###.###.###
Port: 4160
```

Communication and Command Set

The Ethernet interface supports the same command set and syntax as the RS-232 and USB interfaces. Commands are sent as plain text over TCP/IP, terminated with CR/LF, and responses follow the same format.

Establishing a Connection

1. Use a TCP/IP socket connection to connect to the instrument's IP address and port (default port is typically 4160 but verify your device settings).
2. Once connected, the instrument will accept commands in the same format as RS-232/USB.

Note: The command syntax, data formats, and responses are identical to those used in the RS-232 and USB interfaces, simplifying software development and remote operation.

Commands

As previously stated, the following list of commands are valid across all 3 interface formats (RS-232, USB and Ethernet).

Commands and Syntax

- Commands may be terminated with **LF**, **CR**, or **CR/LF**.
- After executing a command, the instrument appends a **CR/LF** to responses.

Entering Commands

- Commands are not case-sensitive.
- One (and only one) space must separate command headers from parameters.

Verifying Connection

To test the connection, send an identification query:

*idn?

The 4160 should respond with: **VALHALLA SCIENTIFIC 4160, 4.01A** (depending on firmware revision)

If no response is received, resend the command. If no response is received, verify power and cable connections.

Details of Command Reference

Each command described in this section will include a detailed explanation, example syntax, and the expected response or query result.

Remote mode is activated when the instrument receives a **valid printable character** via the communication interface. To exit remote mode, use the **LOCAL** front panel key or send the **LOCAL** command.

Alphabetical Commands & Queries Summary Table

Comm/ Query	Type	Syntax	Returns	Notes	Detail on page
*IDN	Q	*IDN?	ID string: Manufacturer, Model, Firmware	Alternate syntax: IDN?, *IDN, IDN	45
Bright	C	Bright <0-15>	<crLf>	Sets display brightness (0=OFF ... 15=100%)	49
Bright?	Q	Bright?	Brightness value (0-15)	Returns brightness percentage	49
Eth?	Q	Eth?	Ethernet IP (x.x.x.x)	Returns 0.0.0.0 if no Ethernet	49
LOCAL	C	LOCAL	<crLf>	Sets device to Local mode; keypad active	45
LOGOFF	C	LOGOFF	<crLf>	Stops continuous logging	52
LOGON	C	LOGON <0-5>	Depends on mode	Starts continuous logging; response depends on value	52
LogSpeed	C	LogSpeed <1-6>	<crLf>	Sets log interval (1=50ms ... 6=1000ms)	53
LogSpeed?	Q	LogSpeed?	Current log speed (1-6)	Returns timing code	53
OHMS?	Q	OHMS?	Resistance in ohms with multiplier	Range formatted; no leading zeros	51
Port	C	Port <xx>	<crLf>	Sets Ethernet port (default=4160)	49
Port?	Q	Port?	Current port	Default = 4160	50
RANGE	C	Range <0-6 or A>	<crLf>	Selects measurement range; Default=A	46
RANGE?	Q	Range?	Current range (0-6, A)	Returns selected range	47
RDNG?	Q	RDNG?	Engineering notation value	e.g., 4.998e-3, 1.0000e+1	52
RESET	C	RESET	Display shows "RESETTING"	Soft reset, restores defaults	46
SCREEN?	Q	SCREEN?	Display data without multipliers	Raw front panel string	51
Serial?	Q	Serial?	Serial number string	e.g., "70-241001"	45

Table 4 - Command & Query Summary Table

System Commands and Queries

IDN*QUERY**

Returns serial identification string from non-volatile.

Syntax: idn?<crLf>

Returns: ID string "VALHALLA SCIENTIFIC 4160,4.01A"

Example: *Idn?<crLf>
"VALHALLA SCIENTIFIC 4160,4.01A"<crLf>

ID_STRING : "VALHALLA SCIENTIFIC"

MODEL : "4160"

FIRMWARE VERSION : "4.01A"

Note Alternate Syntax: IDN, IDN?

Serial?**QUERY**

Returns the Serial Number of the device.

Syntax: Serial?<crLf>

Returns: Serial Number string

Example: Serial?<crLf>

Returns: "71-260101"

LOCAL**COMMAND**

Returns meter to local mode, remote LED off, Keypad functions.

Syntax: LOCAL<crLf>

Returns: <crLf>

Power-on default = LOCAL mode

Remote mode is activated when the meter receives a valid character or command (anything other than <crLf>). In remote mode, all keypad keys are disabled, so no key beeps occur, except for the LOCAL key. Pressing

the LOCAL key in remote mode will switch the device back to local mode, enabling keypad operation.

RESET	COMMAND
--------------	----------------

Executes a soft reset of the device.

Syntax: RESET<cr><lf>

Returns: Front panel display shows soft reset initiation. "RESETTING" is displayed flashing while all system configurations are returned to power up default.

RANGE	COMMAND
--------------	----------------

Selects a measurement range.

Syntax: Range <range number><cr><lf>

Range number = 0 - 7

0 = RANGE_OFF (SAFE MODE)

1 = n/a

2 = R200mOHM

3 = R2_OHM

4 = R20_OHM

5 = R200_OHM

6 = R2K_OHM

7 = R20K_OHM

A = RANGE_AUTO

Power-on default = A

NOTE: RANGE_OFF turns off all Range Relays for no current is sourced out of the device. Range value in top right window is set to SAFE.

RANGE **QUERY**

Returns the selected range.

Syntax: RANGE?<crLf>

Returns: Range number = 0 - 7

0 = RANGE_OFF (SAFE MODE)

1 = n/a

2 = R200mOHM

3 = R2_OHM

4 = R20_OHM

5 = R200_OHM

6 = R2K_OHM

7 = R20K_OHM

A = RANGE_AUTO

Power-on default = A

DISPLAY BRIGHTNESS **COMMAND**

Sets the resting display brightness.

Syntax: Bright <xx><crLf>

Brightness number = 0 - 15

0 = OFF	4 ~ 27%	8 ~ 53%	12~ 80%
1 ~ 7%	5 ~ 33%	9 ~ 60%	13~ 87%
2 ~ 13%	6 ~ 40%	10~ 67%	14~ 93%
3 ~ 20%	7 ~ 47%	11~ 73%	15~ 100%

DISPLAY BRIGHTNESS **QUERY**

Returns the selected resting display brightness.

Syntax: Bright?<crLf>

Returns: Range number = 0 - 15

0 = OFF	4 ~ 27%	8 ~ 53%	12~ 80%
1 ~ 7%	5 ~ 33%	9 ~ 60%	13~ 87%
2 ~ 13%	6 ~ 40%	10~ 67%	14~ 93%
3 ~ 20%	7 ~ 47%	11~ 73%	15~ 100%

ETHERNET IP **QUERY**

Returns Ethernet IP address.

Syntax: Eth?<crLf>

Returns: x.x.x.x

Note: If the Ethernet option is not installed, or the device is not connected to a network, the query will return 0.0.0.0

ETHERNET PORT **COMMAND**

This command allows the user to change the ethernet port setting.

Syntax: port <xx><crLf>

Returns: <crLf>

Default value is 4160.

ETHERNET PORT **QUERY**

Returns Ethernet Port setting.

Syntax: Port?<crLf>

Returns: 4160

Default value is 4160.

Measurement Commands and Queries

OHMS?**QUERY**

Responds with the front panel reading formatted in ohms with multiplier. No leading zeros.

Syntax: OHMS?<crLf>

Returns: <Display data in Ohms with multiplier><crLf>

Example for a 1.1m ohm reading on:

200m Ω Range: 1.10m
2 Ω Range: 0.0011

Example for a 1.1 ohm reading on:

2 Ω Range: 1.1000
20 Ω Range: 1.100
200 Ω Range: 1.10
2k Ω Range: 0.0011k

SCREEN?**QUERY**

Responds with reading from the front panel display. The Ohms omega (Ω), milli (m Ω) and kilo (k Ω) characters are removed during this formatting.

Syntax: SCREEN?<crLf>

Returns: <Display data without multiplier><crLf>

Example for a 1.1m ohm reading on:

200m Ω Range: 001.10
2 Ω Range: 0.0011

Example for a 1.1 ohm reading on:

2 Ω Range: 1.1000
20 Ω Range: 01.100
200 Ω Range: 001.10
2k Ω Range: 0.0011

LOG SPEED**COMMAND**

Sets the speed of the LOG Functions.

Syntax: LogSpeed <speed number><crLf>

Range number = 1 - 6

- 1 = 50msec
- 2 = 100msec
- 3 = 200msec
- 4 = 250msec
- 5 = 500msec
- 6 = 1000msec

LOG SPEED**QUERY**

Returns the selected Log Speed.

Syntax: LogSpeed?<crLf>

Returns: Range number = 1 - 6

- 1 = 50msec
- 2 = 100msec
- 3 = 200msec
- 4 = 250msec
- 5 = 500msec
- 6 = 1000msec

9. General Maintenance and Calibration

General

This chapter provides information on general maintenance and the procedure for calibrating the Model 4160 μ -Ohmmeter.

To ensure continued accuracy, your model 4160 should be calibrated on a routine basis. A **12-month interval** is recommended.

Before performing the calibration procedure, the ohmmeter must be allowed to **warm up for at least 30 minutes** at a stable ambient temperature with all covers in place.

Required Test Equipment

The following equipment is required to perform calibration of the Model 4160:

1. **Precision Resistors** ($\pm 0.005\%$ tolerance)
 - 0.1 Ω
 - 1 Ω
 - 10 Ω
 - 100 Ω
 - 1 k Ω
 - 10 k Ω
2. **DC Voltage Standard**
 - Capable of providing outputs of 0, 50mV, 100mV, and 270mV
3. **Four-Wire Test Lead Set**
4. **Precision Digital Voltmeter (DVM)**

Pre-Calibration Procedure

Calibration adjustments are accessed by removing the **top cover** of the instrument.

- Leave the cover in place as much as possible.
- After each adjustment, replace the cover and allow the instrument to **stabilize** before proceeding.

Warning — Electrical Hazard

Dangerous AC line voltages are present inside the instrument when the cover is removed. Use extreme caution when making adjustments and avoid contact with exposed high-voltage areas.

Calibration Procedure

The standard calibration consists of 2 parts: sense calibration, and source calibration. The sense calibration is cover-on and automated; the instrument will prompt the user throughout the steps. The source calibration is performed by adjusting potentiometers located on the 4160 main board. Both calibrations must be performed for a complete calibration of the 4160.

Sense Calibration

```
Press any Function Key  
or Press CLR to exit
```

Press [Func.]

Press [CAL] to select calibration type.

```
Sens Cal, 200mV Range  
Set Cal input to: 0mV  
[CLR] [ENTER]
```

Connect the voltage source to the Sense terminals of the 4160. Place a jumper from Sense LO to Source HI terminals.

Apply 0mV and press [ENTER]

```
Sens Cal, 200mV Range  
Set Cal input to: 50mV  
[CLR] [ENTER]
```

When prompted, apply 50mV and press [ENTER]

Repeat this step as prompted applying:

100mV, and 200mV.

```
Sense Cal. Complete  
Press [CLR] to exit.
```

Disconnect the voltage source from the Sense Terminals.

Press [CLR] to Exit Sense Calibration.

Source Calibration

1. **Short SENSE HI and SENSE LO** terminals using a jumper.
2. Connect the **DVM** to the main board as follows: DVM negative input to **TP9** DVM positive input to **TP10**.
3. **Adjust RV1** for a DVM reading of **-1.0000V**.
4. Remove the DVM connection and the jumper.
5. Select the **.2Ω range**.
6. Connect the 4160 to a **.1Ω** standard resistor.
7. **Adjust RV2** for a display reading equal to the value of the load.
8. Select the **2Ω range**.
9. Connect the 4160 to a **1Ω** standard resistor.
10. **Adjust RV3** for a display reading equal to the value of the load.
11. Select the **20Ω range**.
12. Connect the 4160 to a **10Ω** standard resistor.
13. **Adjust RV4** for a display reading equal to the value of the load.
14. Select the **200Ω range**.
15. Connect the 4160 to a **100Ω** standard resistor.
16. **Adjust RV5** for a display reading equal to the value of the load.
17. Select the **2kΩ range**.
18. Connect the 4160 to a **1kΩ** standard resistor.
19. **Adjust RV6** for a display reading equal to the value of the load.
20. Select the **20kΩ range**.
21. Connect the 4160 to a **10kΩ** standard resistor.
22. **Adjust RV7** for a display reading equal to the value of the load.
23. **End of Source Calibration.**

Special Procedures

Noisy Readings

Noisy readings are most often caused by poor connections at either the input terminals or the test load.

If excessive noise is observed, verify these connections first.

Inductive Loads

When measuring highly inductive loads (such as large transformers), noisy readings may occur. This results from the high impedance to line voltage exhibited by the load, which increases susceptibility to noise pickup. Using fully shielded cables can greatly reduce this effect.

Additionally, transformer tests may benefit from short-circuiting unused windings during measurement. This reduces the inductance of the winding under test, shortens settling time, and prevents the unused windings from generating hazardous voltages when the ohmmeter is connected or disconnected.

For repair and calibration services, call 800-548-9806 or visit valhallascientific.com.
Email support available at support@valhallascientific.com



4160 Programmable Digital micro-Ohmmeter User Manual
Revision 71-3 (2026)
Copyright © 2026 Valhalla Scientific, Inc. All rights reserved

