

4176

Programmable Micro-Ohmmeter

Rev. 70.3

Operation Manual



VALHALLA
SCIENTIFIC

VALHALLA SCIENTIFIC INC. CERTIFICATION

Valhalla Scientific, Inc. certifies that this instrument was thoroughly tested and inspected and found to meet published specifications when shipped from the factory. Valhalla Scientific, Inc. further certifies that its calibration measurements are traceable to the Nation Institute of Standards and Technology to the extent allowed by NIST's calibration facility.

Due to continuing product refinement and due to possible parts manufacturer changes, Valhalla Scientific, Inc. reserve the rights to change any or all specifications without notice.

VALHALLA SCIENTIFIC INC. WARRANTY STATEMENT

The warranty period for this instrument is stated on your invoice and packing list. Please refer to these to determine appropriate warranty dates.

We will repair the instrument during the warranty period provided it is returned to Valhalla Scientific, Inc. freight prepaid. No other warranty is expressed or implied.

Valhalla Scientific, Inc. is not liable for consequential damages.

Permission and a Return Material Authorization number (RMA) must be obtained directly from the factory for warranty repairs. No liability will be accepted if returned without such permission.

Due to continuing product refinement and due to possible parts manufacturer change, Valhalla Scientific reserves the right to change any or all specifications without notice.

SUPPORT

For repair and calibration services, call 800-548-9806 or visit valhallascientific.com.

Email support available at support@valhallascientific.com



4176 Programmable Digital micro-Ohmmeter User Manual
Revision 70-3 (2026)
Copyright © 2026 Valhalla Scientific, Inc. All rights reserved

WARNINGS

The following general safety precautions must be observed during all phases of operation, service, and repair of this product. Failure to comply with these precautions or with specific warnings elsewhere in this manual violates safety standards of design, manufacture, and intended use of the product. Valhalla Scientific assumes no liability for the customer's failure to comply with these requirements.

Ground the equipment: For Safety class 1 equipment (equipment having a protective earth terminal), an interrupted safety earth ground must be provided from the main power source to the product input wiring terminals or supplied power cable.

For continued protection, replace the line fuse(s) only with fuse(s) of the same voltage and current rating and type. DO NOT use repaired fuses or short-circuited fuse holders.

Keep away from live circuits: Operating personnel must not remove equipment covers or shields. Procedures involving the removal of covers or shields are for the use of service-trained personnel only. Under certain conditions, dangerous voltage may exist even with the equipment switched off. To avoid dangerous electrical shock, DO NOT perform procedures involving cover or shield removal unless you are qualified to do so.

DO NOT operate damaged equipment: Whenever it is possible that the safety protection features built into this product have been impaired, either through physical damage, excessive moisture, or any other reason, REMOVE POWER and do not use the product until safe operation can be verified by service-trained personnel. If necessary, return the product to Valhalla Scientific for service and repair to ensure that safety features are maintained.

DO NOT service or adjust alone: Do not attempt internal service or adjustment unless another person, capable of rendering first aid and resuscitation, is present.

DO NOT substitute parts or modify equipment: Because of the danger of introducing additional hazards, do not install substitute parts or perform any unauthorized modification to the product. Return the product to Valhalla Scientific for service and repair to ensure that safety features are maintained.

Measuring high voltage is always hazardous: ALL multimeters input terminals (both front and rear) must be considered hazardous whenever inputs greater than 42V (dc or peak) are connected to ANY input terminal.

Permanent wiring of hazardous voltage or sources capable of delivering greater than 150VA should be labeled, fused, or in some other way protected against accidental bridging or equipment failure.

DO NOT leave measurement terminals energized when not in use.

Table of Contents

Table of Contents.....	3
General Information	7
Instrument Description	7
Instrument Identification.....	7
Safety Precautions	7
Unpacking and Installing.....	8
Inspection.....	8
Setting the Line Voltage.....	8
Fuse Selection	8
Bench Use	9
Rack Mounting.....	9
Specifications	10
Standard Measurement Mode Specifications	10
Temperature Compensator Mode Specifications.....	10
General Specifications.....	11
Environmental.....	11
Power Requirements	11
Physical	11
Getting Started.....	12
Introduction	12
Front Panel Overview.....	12
Power Switch	12
Display.....	13
Range Selection Keys	13
Function/Numerical Keys.....	14
TCM Receptacle and LEDs.....	15
HLC LEDs.....	16
Remote LED.....	16
Source and Sense Binding Post	16
Rear Panel.....	17
Line Voltage Switch.....	17
Fuse Holder	17

Power Connector	17
RS-232 Connector	17
USB Interface	17
Ethernet Port (Optional)	18
Interlock Current Disable (ICD) Terminals (Optional)	18
HLC Relay Terminal (Optional)	18
Applying Power	19
Power-On Settings	19
Changing the Power-On Settings	19
Reset to Factory Defaults:	19
Connecting a Load to the 4176	19
Range Selection.....	21
Overload.....	21
Safe Mode.....	21
Measurement Modes and Functions.....	22
Standard Measurement Mode	22
“TCM” — Temperature Compensated Measurement Mode	23
Omni Compensator	24
Enabling TCM Mode.....	24
Temperature Compensator Setup	24
Temperature Compensator Calibration.....	26
“HLC” – Hi-Lo Comparator Mode.....	27
Min/Max HLC Setup	28
Nominal $\pm\%$ HLC Setup.....	29
HLC Default Settings and Limits.....	30
HLC Relay Terminal (Optional).....	30
Display Brightness and Screen Saver Mode.....	31
Run / Hold Feature.....	31
PeakHi/PeakLo Function	31
Send Function	32
Send Function Setup	32
LOG Function.....	33
LOG Function Setup	34

Log/Send Interface Port Selection Function	34
View Function	35
Optional Features and Accessories.....	36
Options.....	36
Ethernet Interface.....	36
HLC Relay Terminal	36
Interlock Current Disable (ICD) Terminals	36
Accessories.....	36
Omni TC.....	36
Option RX-3: Rack Mount Adapter	36
Test Leads	37
Alligator Clip Type Leads.....	37
Needle Type Probes	37
Surface Probes	38
Other Lead Sets.....	38
Remote Interface	39
RS-232 Interface.....	39
USB Interface	40
Ethernet Interface (Optional)	41
Commands	43
Alphabetical Commands & Queries Summary Table	44
System Commands and Queries	46
Measurement Commands and Queries.....	52
HLC Commands and Queries.....	55
TCM Commands and Queries	57
Keypad Commands	61
General Maintenance and Calibration.....	62
General.....	62
Calibration Procedure	63
Sense Calibration	63
Source Calibration.....	64
Optional TCM Sense Calibration	65
Special Procedures.....	66

Noisy Readings	66
Inductive Loads	66

General Information

Instrument Description

Welcome to the world of low resistance measurement! The precision instrument you have purchased offers exceptionally stable measurement capabilities for challenging items such as transformers, coils, shunts, and even the resistance of wire itself. Additional features include programmable temperature compensation, hi-lo comparison, and remote interface options.

Please read this manual thoroughly, along with all accompanying addendums, before attempting to operate the ohmmeter.

Instrument Identification

Valhalla Scientific instruments are identified by a two-part serial number located on the Serial Tag, found on the rear or bottom of the device.

The serial number is formatted as **70-XXXXXX**,

where:

The first two digits (the serial number prefix) indicate the model and change only when modifications are made to the instrument.

The last six digits (the serial number suffix) are unique to each individual unit.

Be sure to include the entire serial number—both prefix and suffix—in any correspondence regarding your instrument.

Safety Precautions

The power plug must be a three-contact device and should only be inserted into a matching socket that provides a proper ground connection via the third contact. When using an extension cord, ensure that the ground connection remains continuous; any break in the ground lead could render the unit unsafe.

Testing inductive loads, such as transformers, requires special precautions to prevent damage to the instrument and avoid injury to the operator. For detailed safety procedures, please refer to Chapter 7.

Unpacking and Installing

Inspection

If the shipping carton is damaged, request that the carrier's agent be present during unpacking. If the instrument appears damaged, the carrier's agent should approve any repairs before the unit is returned to the factory. Even if the instrument looks undamaged externally, internal damage may have occurred during transit and might not be visible until the unit is operated or tested to verify compliance with its specifications.

If the unit fails to operate or does not meet the specified performance standards, notify both the carrier's agent and the nearest Valhalla Sales Office. Retain the original shipping carton for carrier inspection.

Important: Do not return the equipment to Valhalla Scientific, Inc., or any of its sales offices without prior authorization.

Setting the Line Voltage

The line voltage selection is preconfigured based on the destination country or as specified by the customer.

To change this setting:

1. Disconnect the power cord from the instrument.
2. Using a small flat-head screwdriver, slide the **“Line Voltage Selector”** switch to the appropriate position.
3. Replace the line fuse accordingly.

Fuse Selection

Before operation, verify the following:

- The instrument is set for the correct local AC line voltage, selected via the rear panel switch:
115V - 105 Vac to 125 Vac
230V - 210 Vac to 250 Vac
- The proper fuse is installed:
115 Vac: 0.5 Amp Slo-Blo fuse
230 Vac: 0.25 Amp Slo-Blo fuse

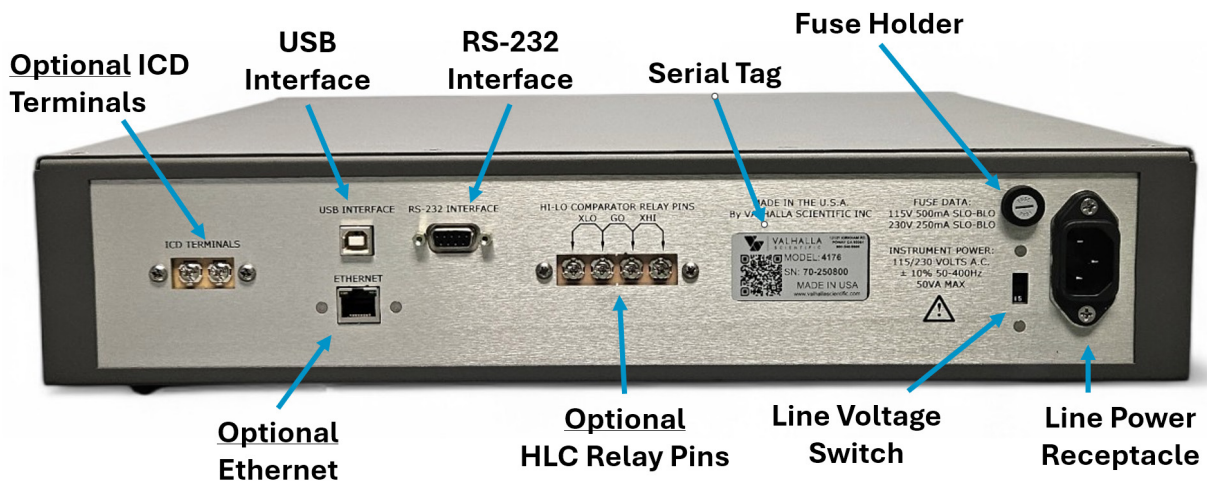

Bench Use

The ohmmeter is supplied with all necessary hardware for bench use. No special instructions are required for standard bench operation. However, it is recommended that users familiarize themselves with Chapters 3 and 4 before operating the instrument.

Rack Mounting

Optional brackets are available for mounting the ohmmeter in a standard 19" equipment rack. The rack mount kit (model RX-3) includes two brackets and four flat-head screws, which can be easily installed on the front ends of each side rail (see Figure 1).

To promote proper airflow and prevent overheating, install blank panels at least 1.75 inches high between this unit and adjacent rack-mounted devices. Under no circumstances should the ambient temperature around the unit exceed **50°C** during operation or **70°C** when powered off.

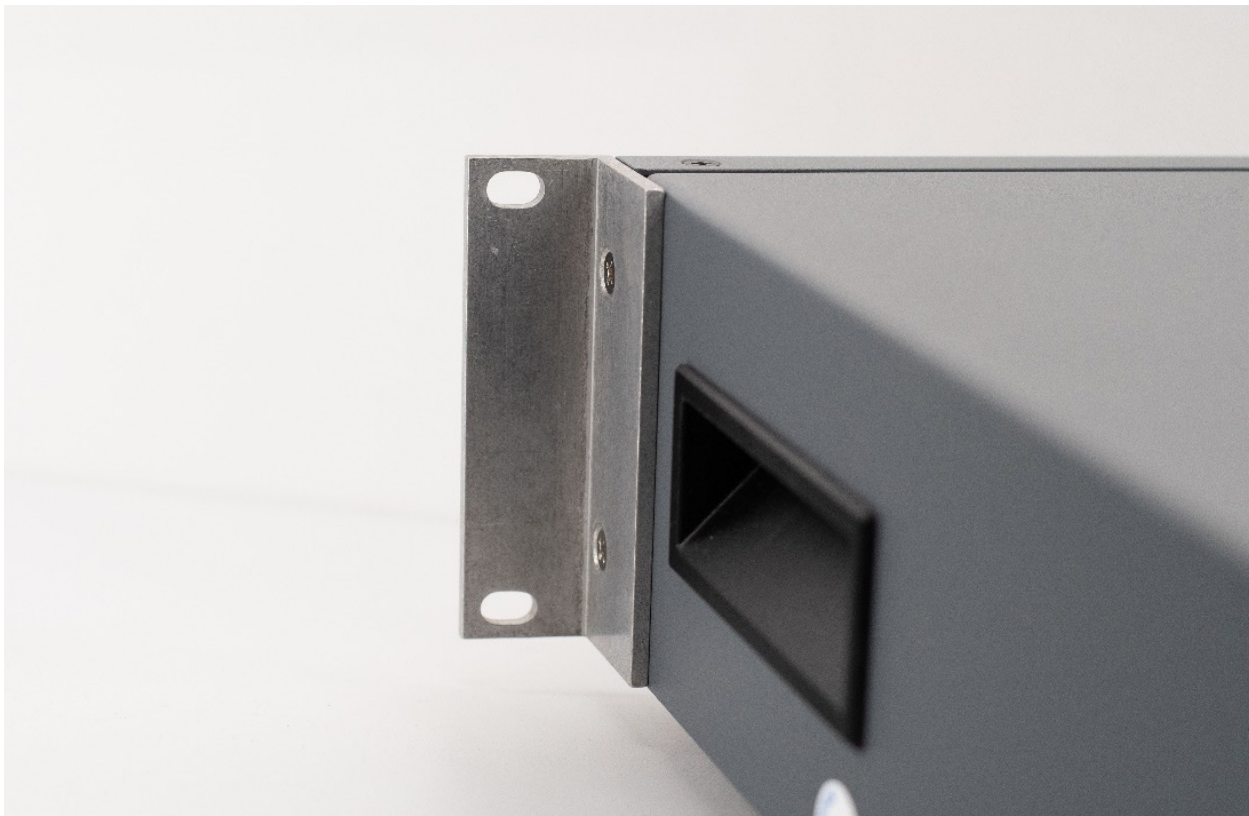

Figure 1 - Rack Mount Adaptor RX-3

Specifications

The specifications for the 4176 Programmable μ -Ohmmeter are detailed in the following sections. All specifications are valid for full Kelvin Four-Terminal measurements using connections with less than 20m Ω of lead resistance per wire.

Standard Measurement Mode Specifications

#	Range	Test Voltage	Full Scale	Resolution	Current Source ¹	Accuracy ² \pm (% of Reading + Ω)	Temperature Coefficient ³
1	20m Ω	20mV	20.000m Ω	1 $\mu\Omega$	1A	\pm (0.02% + 0.004m Ω)	\pm 20ppm/ $^{\circ}$ C
2	200m Ω	200mV	300.00m Ω	10 $\mu\Omega$	1A	\pm (0.02% + 0.04m Ω)	\pm 20ppm/ $^{\circ}$ C
3	2 Ω	200mV	3.0000 Ω	100 $\mu\Omega$	100mA	\pm (0.02% + 0.0004 Ω)	\pm 20ppm/ $^{\circ}$ C
4	20 Ω	200mV	30.000 Ω	1m Ω	10mA	\pm (0.02% + 0.004 Ω)	\pm 20ppm/ $^{\circ}$ C
5	200 Ω	200mV	300.00 Ω	10m Ω	1mA	\pm (0.02% + 0.04 Ω)	\pm 20ppm/ $^{\circ}$ C
6	2k Ω	200mV	3.0000k Ω	100m Ω	100 μ A	\pm (0.02% + 0.0004k Ω)	\pm 20ppm/ $^{\circ}$ C
7	20k Ω	200mV	30.000k Ω	1 Ω	10 μ A	\pm (0.02% + 0.004k Ω)	\pm 20ppm/ $^{\circ}$ C

Table 1 - Ranges Parameters and Accuracies

Temperature Compensator Mode Specifications

#	Range	Accuracy
1	20m Ω	\pm [0.02% of Reading + 0.007m Ω + (0.0002m Ω x Δ T)]
2	200m Ω	\pm [0.02% of Reading + 0.07m Ω + (0.002m Ω x Δ T)]
3	2 Ω	\pm [0.02% of Reading + 0.0007 Ω + (0.00002 Ω x Δ T)]
4	20 Ω	\pm [0.02% of Reading + 0.007 Ω + (0.0002 Ω x Δ T)]
5	200 Ω	\pm [0.02% of Reading + 0.07 Ω + (0.002 Ω x Δ T)]
6	2k Ω	\pm [0.02% of Reading + 0.0007k Ω + (0.00002k Ω x Δ T)]
7	20k Ω	\pm [0.02% of Reading + 0.007k Ω + (0.0002k Ω x Δ T)]

Δ T is the absolute value of the difference between the ambient temperature in $^{\circ}$ C and 25 $^{\circ}$ C.

¹ Current Source is \pm 1% absolute accuracy.

² The accuracy specifications listed are valid following a 30-minute warm-up at an ambient temperature between 15 $^{\circ}$ C and 35 $^{\circ}$ C and include the effects of line voltage variations within the allowed range.

³ Temperature Coefficient specified for temperature ranges from 5 $^{\circ}$ C to 21 $^{\circ}$ C and 29 $^{\circ}$ C to 50 $^{\circ}$ C.

General Specifications

Display:.....5 Digit / Multi Section OLED Display

Overload Limit:

20mΩ Range..... 99.995 % of Range

200mΩ through 20kΩ Range: 149.995 % of Range

Overload Indication:Displays O.L.

Terminal Configuration:Four-wire Kelvin

ADC Conversion Rate:100msec

Display Update:100msec

Compliance Voltage: 5 VDC nominal

Settling Time 300mSec

Environmental

Operating Temperature Range: 0 to 50°C

Storage Temperature Range:.....-40°C to 85°C

Humidity:..... 80% RH at 40°C non-condensing

Power Requirements

Power Supply Voltage:105-125 or 210-250 VAC

Power Supply Frequency:50 - 60 Hz Power

Supply Consumption: 25VA Maximum

Physical

Dimensions:..... 17"(43cm) W x 17"(43cm) D x 4"(10cm) H

Weight:..... 4.7Kg (10.4 lbs.) Net; 7Kg (15 lbs.) Shipping

Getting Started

Introduction

This chapter provides an overview of the fundamental operation of the ohmmeter. It details how to utilize both the front and rear panels, establish proper connections, and interpret the display sections and messages. Before proceeding with measurements, it is helpful to familiarize yourself with each section of the 4176's front and rear panels.

Front Panel Overview

The front panel of the 4176 is divided into eight distinct sections. Refer to Figure 2 for a visual layout, with each area labeled accordingly.

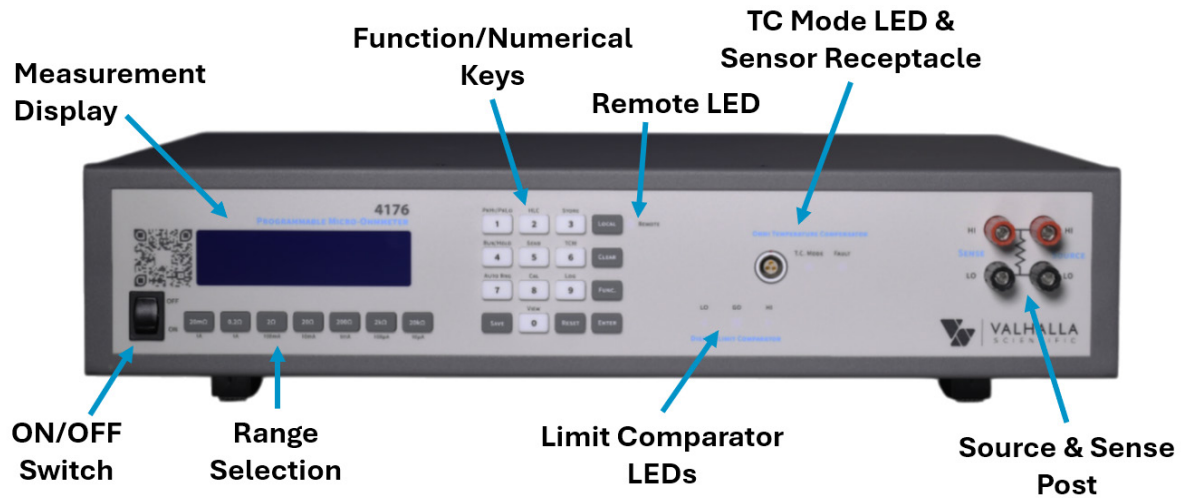

Figure 2 - 4176 Front Panel

Power Switch

The power switch is a two-position rocker switch labeled ON and OFF. It controls the application of AC power to the ohmmeter's internal circuitry—moving to the ON position supplies power, while the OFF position disconnects it.

Display

During measurements, the display features four distinct sections, each serving a specific purpose:

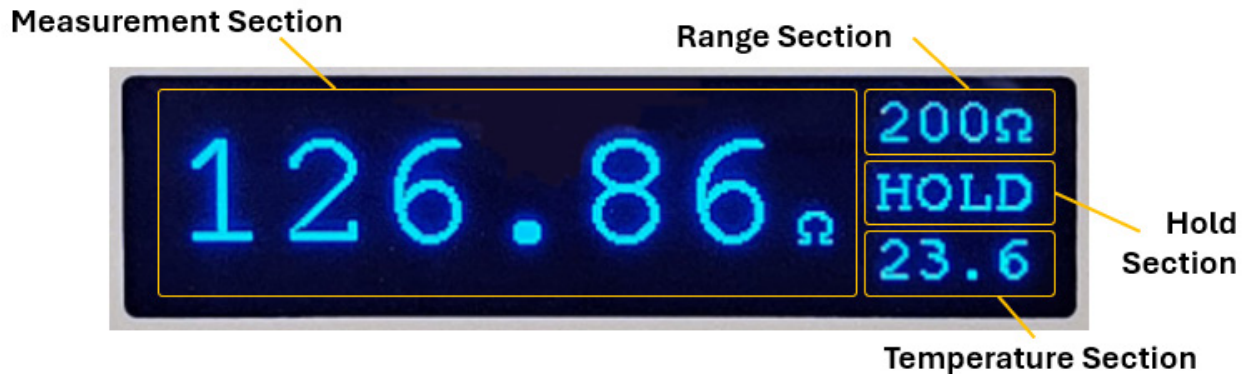

Figure 3 - Display Layout

Measurement Section

This section displays the measured value of the load.

Range Section

This section displays range related information. Primarily, the selected range. Other callouts are:

- **AUTO** indicates that the device is in auto range.
- **SAFE** indicates that range 0 has been selected via serial command. Test Current is disabled.
- **ICD** indicates that the test current has been disabled by the ICD Interface (Optional)

Run Hold Section

This section shows **HOLD** when the hold function is triggered. Black indicates that the device is in Run mode.

Temperature Section

This section will show the measured ambient temperature when temperature compensation mode is on.

The display also functions as a prompt system, providing alerts and messages to guide the user.

Range Selection Keys

The seven range keys allow the user to manually select the desired measurement range. Each key is labeled with the corresponding range value and current source setting.



CAUTION:

Extra care should be taken when working with inductive loads. Always select the highest resistance range before connecting or disconnecting the test leads to prevent damage or inaccurate readings.

Function/Numerical Keys

There are sixteen Function/Numerical keys used to trigger the standard and/or optional ohmmeter functions and for data entry. Table 2 lists a brief description of each key and its uses. The Function/Numerical keys will be further described throughout this manual.

Key	Num. Value	Idle State	Function Menu	View Menu
FUNC.	-	Enter Function Menu	-	-
PKHI/PKLO	1	Toggle Peak Hi/Lo (disables auto-range)	Enter Peak Hi/Lo Configuration	-
HLC	2	Toggle HLC (disables relays)	Enter HLC Configuration	View HLC settings
STORE	3	Enter Store Power-Up Data Confirm state	-	-
RUN/HOLD	4	Toggles Run/Hold	-	-
PRINT	5	Send/Print current reading (format depends on config)	Enter Send/Print Format Selection	View Send/Print settings
TCM	6	Toggle TCM (disables auto-range)	Enter TCM Calibration (guided steps)	View TCM settings
AUTO RNG	7	Toggle auto-range	Enter Range 0 (Save Mode)	-
CAL	8	-	Enter Internal Calibration (guided steps)	-
LOG	9	Toggle logging	Enter Log Format Selection	View Log settings
VIEW	0	Enter View Menu	Enter Brightness Configuration	-
RESET	-	Soft reset device	Enter Factory Reset Confirmation	-
LOCAL	-	Exits Remote Mode	Enter UART Port Selection	View Ethernet/IP info
CLEAR	-	-	Return to Idle	Return to Idle
ENTER	-	-	-	-
SAVE	-	-	-	-

Table 2 - Key Summary Table

TCM Receptacle and LEDs

This section of the front panel is used exclusively during temperature-compensated measurements (TCM). For detailed information about this measurement mode, refer to the "Temperature Compensated Measurement Mode" section of the manual.

Accurate temperature sensing is critical for TCM measurements, requiring secure and reliable connections between the sensing device and the instrument. The temperature sensor receptacle is designed to ensure proper connection; the Valhalla Scientific Omni-TC⁴ sensor can only be inserted in the correct orientation. To assist with proper insertion, a red dot on the Omni-TC and a red tab on the receptacle guide you into the correct mating position.

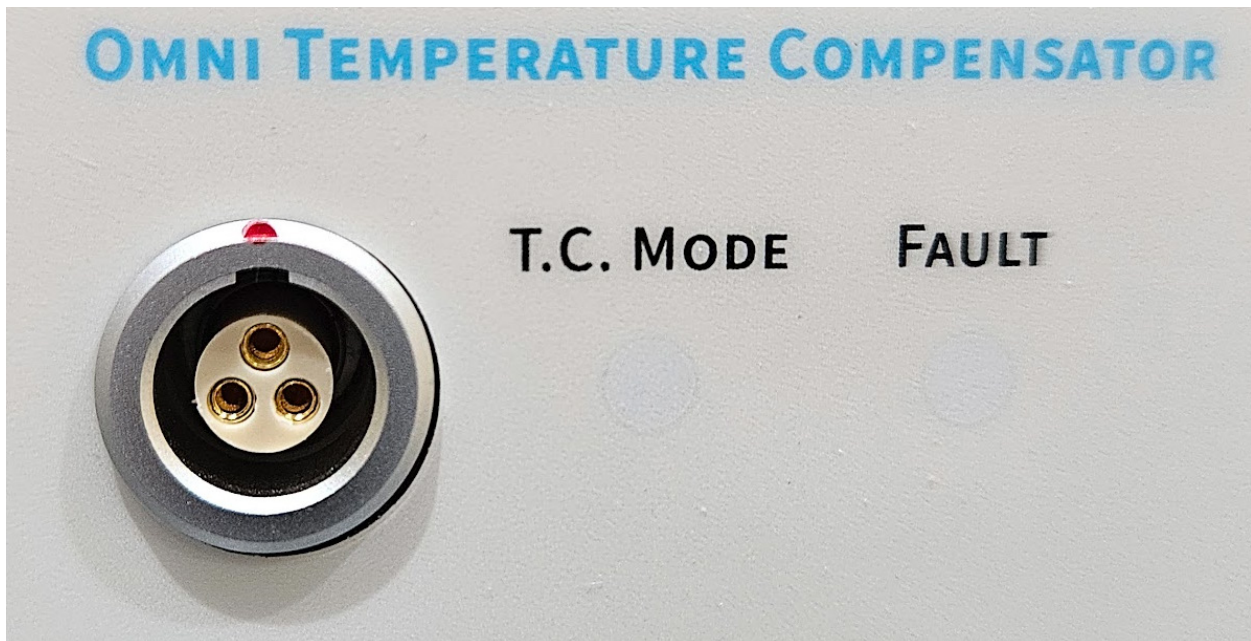

Figure 4 - Front Panel TCM Area

The TCM feature of the 4176 calculates resistance values by factoring in the ambient temperature and other parameters discussed in later chapters. It is important for the user to be aware of whether the TCM mode is enabled or disabled, as this affects the interpretation of the displayed readings.

The **green LED**, labeled "T.C. Mode", indicates when the TCM mode is active. Conversely, the **red LED**, labeled "Fault", signals issues such as missing contacts between the sensor and the instrument.

CAUTION:

Values displayed while the "Fault" indicator is illuminated should not be considered valid under any circumstances.

⁴ The Omni-TC is an optional accessory to the 4176.

HLC LEDs

This part of the front panel provides a visual indication of the Hi-Lo Comparator (HLC) results. HLC mode is explained in detail in the **Measurement Modes and Functions** section of this manual. The HLC LEDs are only active when the HLC mode is enabled.

- The **green LED**, labeled “**GO**”, illuminates if the measured resistance falls within the user-defined limits.
- The **red LED**, labeled “**LO**”, lights up if the measurement is below the lower limit.
- The **red LED**, labeled “**HI**”, activates if the measurement exceeds the upper limit.



Figure 5 - Front Panel HLC Area

Only one LED should be illuminated at a time. If more than one LED remains on for an extended period, it is recommended to contact the Valhalla Scientific Tech Support Team for assistance.

Remote LED

The Remote LED indicates the operational mode of the instrument:

- When **on**, the instrument is in **remote mode** and can only accept commands via its remote interface port.
- When **off**, the instrument is in **local mode** and responds only to commands entered from the front panel keys.

Source and Sense Binding Post

Connections to the 4176 are made through the front panel source/sense terminals. These consist of two red and two black binding posts, each with gold-plated brass contacts. The posts accept standard banana plugs, wires up to 12 AWG, or spade lugs.

The four terminals support **full 4-wire Kelvin measurement**:

- The **right posts** are the positive and negative current source terminals, supplying the test current.
- The **left posts** are the positive and negative voltage sense terminals, used to monitor the voltage drop across the load.

This 4-wire configuration eliminates measurement errors caused by lead and contact resistances. In many cases, contact resistance can be significantly higher than the load resistance. The 4176 minimizes this error by providing separate current source and voltage sensing terminals, ensuring fast and accurate resistance measurements independent of lead, wire, or contact resistance.

Chapter 5 of this manual will further explain how the 4-wire measurement principle is used to eliminate potential errors from lead and contact resistances.

Rear Panel

The rear panel of the 4176 may vary depending on the optional features installed. This section describes the standard model without any additional options or modifications. If your unit features terminals or connectors not covered here, please refer to any applicable addendum specific to your model.

Line Voltage Switch

The line voltage switch allows you to select the appropriate power setting based on your local AC mains voltage.

- Sliding the switch upward displays "115" and configures the instrument for **115VAC ± 10%**.
- Sliding the switch downward displays "230" and configures the instrument for **230VAC ± 10%**.

Before powering on the ohmmeter, verify that the switch is set correctly for your local line voltage.

WARNING:

Using the incorrect line voltage setting can cause damage to the instrument!

Fuse Holder

The fuse holder on the rear panel provides access to the main power fuse. The fuse values are specified as follows:

- **115 VAC:** 0.250 Amp Slow-Blow Fuse
- **230 VAC:** 0.125 Amp Slow-Blow Fuse

WARNING:

Always replace blown fuses with an exact equivalent to ensure safe and proper operation.

Power Connector

The 3-prong power connector on the rear panel is used to supply AC power to the instrument. The included power cord mates with this connector. For details on available voltages and safety precautions, refer to **Chapter 1**.

RS-232 Connector

The RS-232 serial interface is accessible via the 9-pin female D-Sub connector located on the rear panel. For certain applications, understanding the specific pin functions may be necessary; refer to **Chapter 7: Remote Interface** for detailed pin assignments.

USB Interface

This interface allows for easy data transfer, configuration, and control of the instrument via standard USB connections.

The USB port supports plug-and-play functionality and is compatible with most modern operating systems. For proper operation, use a standard USB Type B cable to connect the instrument to your computer's USB port.

Refer to **Chapter 7: Remote Interface** for detailed instructions on establishing a connection and configuring communication settings.

Ethernet Port (Optional)

The 4176 may be equipped with an optional Ethernet port located on the rear panel to enable network connectivity. This port allows the instrument to be integrated into local networks for remote monitoring, data logging, or control via standard Ethernet protocols.

The Ethernet port supports standard RJ45 connectors and complies with typical network configurations. To establish a connection, use an appropriate Ethernet cable to connect the instrument to your local area network (LAN).

For detailed setup instructions, including IP address configuration, network settings, and communication protocols, refer to **Chapter 7: Remote Interface** or the network configuration guide provided with your instrument. Proper setup ensures reliable communication and seamless integration into your existing network infrastructure.

Interlock Current Disable (ICD) Terminals (Optional)

If the ICD option is installed on your 4176, the rear panel will feature a pair of terminals designated for this function. To enable the output current from the instrument, these terminals must be shorted together. When the terminals are open, the current output is disabled.

HLC Relay Terminal (Optional)

The HLC (High-Low Comparator) relay terminal is internally connected to three relays, which are active only when the HLC mode is enabled. Based on the measurement comparison:

- One relay's contacts will close if the measured load value (Ω) falls within the set limits.
- The other two relays will remain open.

HI-LO Comparator Relay Pins

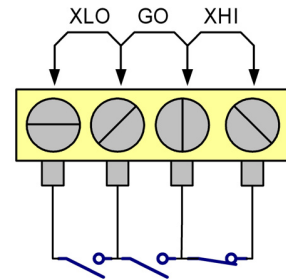

This relay contact closure capability facilitates automated sorting or control processes at an economical cost. The screw-type terminals are designed for connections to wires or spade lugs.

Electrical Ratings:

- **Voltage:** 100 V
- **Current:** 100 mA

HLC State and Result Truth Table:

HLC State	HLC Result	XLO	GO	XHI
ON	$LL \leq \Omega \leq UL$	OPEN	CLOSED	OPEN
ON	$\Omega < LL$	CLOSED	OPEN	OPEN
ON	$\Omega > UL$	OPEN	OPEN	CLOSED
OFF	$LL \leq \Omega \leq UL$	OPEN	OPEN	OPEN
OFF	$\Omega < LL$	OPEN	OPEN	OPEN
OFF	$\Omega > UL$	OPEN	OPEN	OPEN

(Note: " Ω " represents the load measurement; UL and LL are the user-set upper and lower limits.)

Applying Power

Before powering on the instrument, please refer to **Chapter 2** for safety and setup instructions.

To turn on the ohmmeter, set the front panel power switch to the **ON** position. If the device does not power up, verify that it is properly connected to the power line. If power connection is confirmed but the instrument still does not start, check the line power fuse and ensure that the line voltage selection switch is set correctly for your local voltage.

Power-On Settings

When the ohmmeter is powered on, it initializes with the following factory default settings:

Function	Default Setting
Range	20 k Ω
Auto-Range	ON
Temperature Compensation Mode (TCM)	OFF
Hi-Lo Comparator Mode (HLC)	OFF
Peak/HiLo Mode (PkHiLo)	OFF

Changing the Power-On Settings

These defaults are set at the factory and are automatically applied at power-up. However, you can customize and store your preferred settings at any time using the **Store** function, which saves the current configuration for future power cycles.

Reset to Factory Defaults:

To revert the instrument back to its original factory power-on settings, press the **Func.** button, then the **Reset** button. This will restore all settings to their default values.

Connecting a Load to the 4176

The first step in using the ohmmeter is to connect it to the load or device under test. Valhalla Scientific, Inc. offers a variety of test leads compatible with the Model 4176 and other Valhalla ohmmeters. Refer to **Chapter 5** for a list of available test leads.

All ohmmeter test leads consist of a pair of conductors terminated with multi-stacking dual banana plugs. It is essential to observe the position of the ground marker on each plug to ensure proper connection. The marked side of each banana jack should be connected to the respective **Source** terminals.

Connecting the Leads:

- **Lead 1:** Connect between **SENSE HI** and **SOURCE HI**, with the ground marker on the source side.
- **Lead 2:** Connect between **SENSE LO** and **SOURCE LO**, with the ground marker on the source side.

This configuration ensures that the current source is carried through the largest conductor in the cable, and the sense input remains shielded from interference.

The opposite ends of the leads may have different types of terminations. On the following page, a description of the three most common termination styles will be provided.

Common Termination Styles for Test Leads

The most common termination is alligator clip connectors. If you choose this type of lead, simply attach one clip to one side of your load and the other clip to the opposite side.

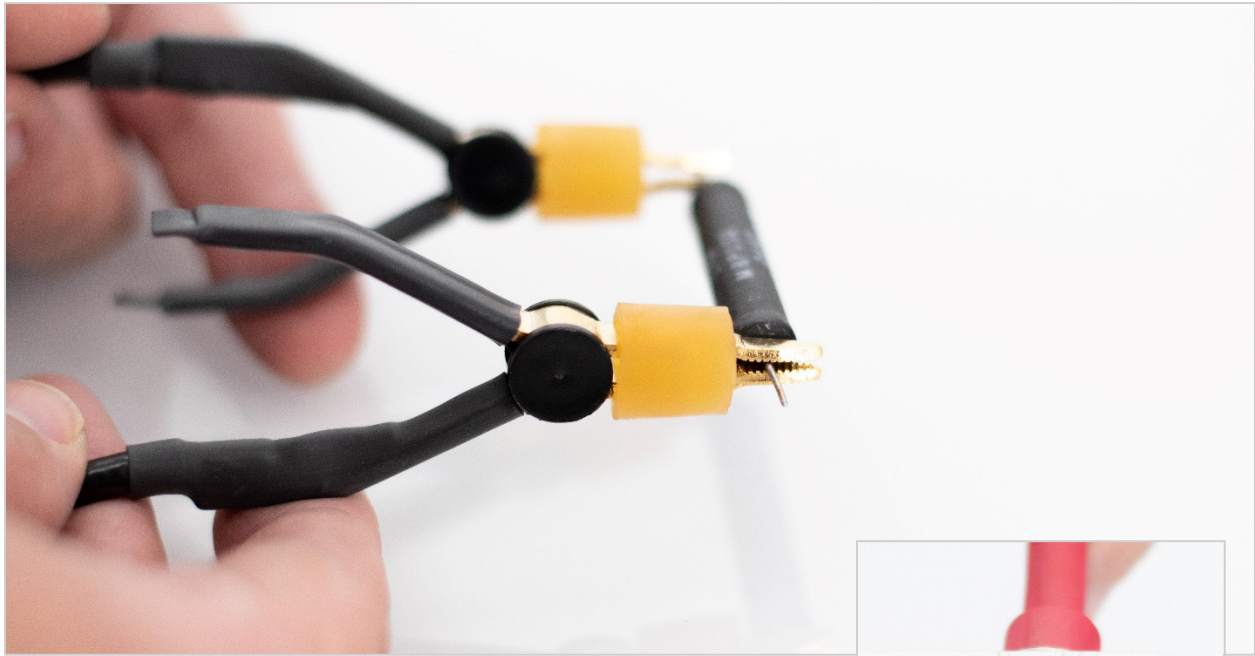

Surface Probes

For measurements on flat surfaces, Valhalla Scientific offers two types of spring-loaded surface probes. To use these:

- Press one probe firmly against one side of the surface of your load, ensuring full contact between the probe surface and the load surface.
- Press the second probe against the opposite side of the load, again ensuring full contact.



Needle Probes

For hard-to-reach surfaces, Valhalla Scientific provides two sets of spring-loaded dual needle probes. These differ in overall size and the distance between the needles. To use them:

- Press both needles of one probe against one end of the load's surface.
- Press both needles of the second probe against the opposite end of the load's surface.

Note:

For a complete list of available lead sets and accessories for the 4176, see **Chapter 5**.

Range Selection

By default, the factory setting for the 4176 is to start in **Auto-Range** mode. In this mode, the display's range window shows **"AUTO"**, and the instrument automatically selects the range that provides the highest resolution for the measured resistance.

In applications where the test current is critical, it may be beneficial to manually select a specific range. You can do this by pressing the appropriate range key, which is labeled with the range value and the corresponding test current. The chosen range will be displayed in the range window.

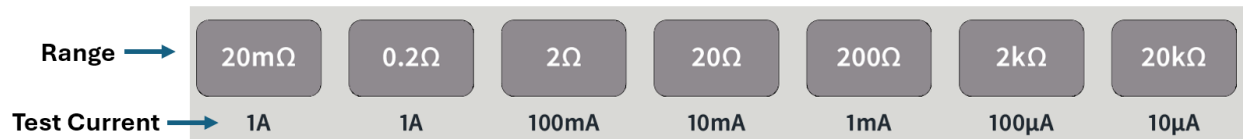

For consistent operation, you can set a preferred range and store it for future use by using the **Store** function while in that range.

To switch back to **Auto-Range** mode at any time, press the **"AUTO RNG"** key on the front panel.

Overload

If the load value exceeds the selected range limit, the instrument enters an **Overload** state. During overload, the display will repeatedly flash the word **"OVERLOAD"**. In this case, you should:

- Select a higher range, or
- Press the **Auto** key to allow the instrument to automatically select an appropriate range.

If the load exceeds the highest available range, promptly disconnect the load from the instrument to prevent damage.

If the load value exceeds the limit of the highest range, promptly disconnect the load from the instrument to avoid damage to the equipment.

Important Note:

If no load is connected to the 4176, the display may also read **"OVERLOAD"**. This is normal and does not indicate a fault with the device. It simply means that there is no load present.

Safe Mode

The 4176 can be placed in **Safe Mode** by pressing the **Func.** key, followed by the **Auto Rng** key.

In Safe Mode, the device will not source current, and the display will indicate **"Safe"** in the top right corner. This mode is useful for maintenance, troubleshooting, or preventing measurements during certain operations.

To exit Safe Mode and resume normal operation, select any range or press the **Auto Rng** key again.

Measurement Modes and Functions

The primary feature of the 4176 is its capability to perform **4-wire resistance measurements**. In addition to standard measurements, the 4176 offers **Temperature Compensation Mode (TCM)** and **Hi-Lo Comparator Mode (HLC)**. These advanced features can significantly reduce measurement time and cost, especially in temperature-sensitive or automated applications.

Standard Measurement Mode

The 4176 powers on in **Standard Measurement Mode**⁵, which measures the load value using a 4-wire configuration. This setup effectively eliminates errors caused by test lead and contact resistance, which in many applications can be several orders of magnitude greater than the load resistance.

The 4-wire measurement technique involves:

- **Two terminals** dedicated to a **constant current source** (positive and negative).
- **Two additional terminals** for **high-impedance voltage sensing**.

This configuration ensures that the measurement is unaffected by lead, wire, or contact resistances, providing a fast and highly accurate resistance reading.

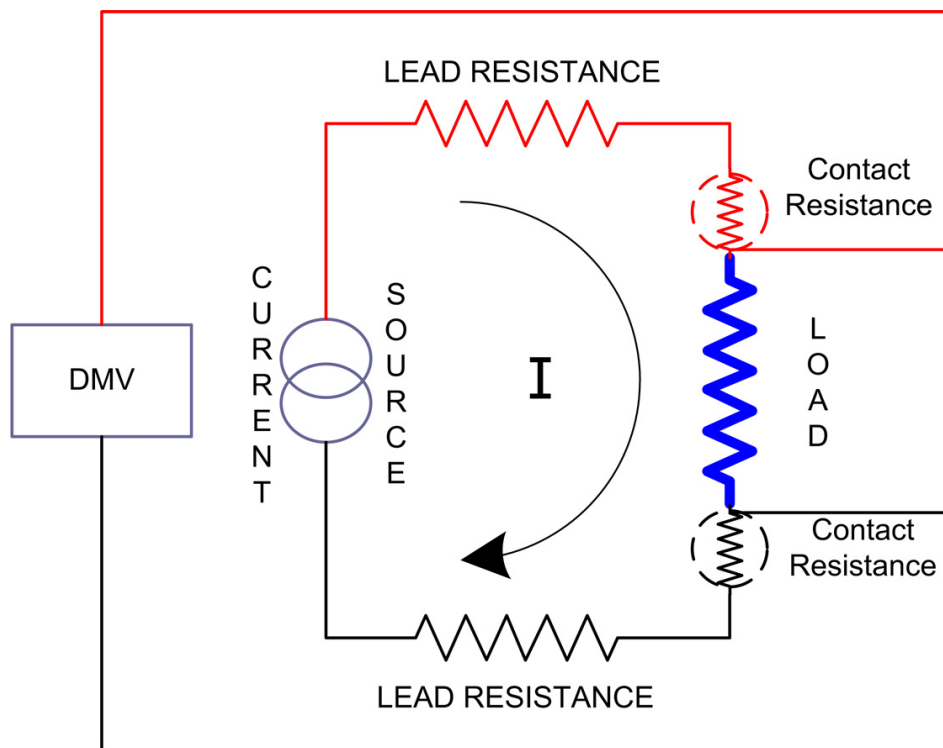

The illustration above (not shown here) demonstrates how the 4-wire method minimizes errors from lead, wire, and contact resistances. The internal current source delivers a precise, constant current that overcomes series resistance within compliance voltage limits. The high-impedance voltage measurement input of the digital voltmeter (DVM) senses the voltage drop across the load, with negligible error introduced by contact or lead resistance due to its high input impedance.

⁵ Default power up configure can be changed. See “Changing the Power-On Settings” section of this manual.

“TCM” — Temperature Compensated Measurement Mode

Valhalla engineers are pioneers in the technology of accurate measuring devices using recognized formulas that compensate for measurement inaccuracies because of environmental changes. The TCM feature simulates a constant ambient temperature chamber for materials which are normally subject to varying ambient temperatures. When in the TCM mode, the temperature sensor, the Omni-TC[™], senses the ambient temperature and automatically compensates the reading to indicate what the actual resistance value should be in a controlled environment (usually 20° C). The compensated value is calculated with the following equation:

$$\frac{\Delta R}{R_0} = \alpha \Delta T$$

The variation of resistance (ΔR) divided by the initial resistance (R_0), is equal to the temperature coefficient of the material (α) multiplied by the variation of temperature (ΔT).

Expressed in terms of the resistance:

$$\frac{R - R_0}{R_0} = \alpha(T - T_0) \text{ OR } R = R_0[1 + \alpha(T - T_0)]$$

To better understand our uses of the equation, we will now express it in terms of our application.

$$R_M = R_C[1 + \alpha(T_A - T_R)]$$

Where R_C is the compensated value, R_M is the measured resistance, T_A is the ambient temperature and T_R is the temperature reference.

The compensated resistance is therefore calculated as follows:

$$R_C = \frac{R_M}{1 + \alpha(T_A - T_R)}$$

The user can select from a list of temperature coefficients and temperature references. The list is based on the most used values. The user can also customize these settings with unique values.

Once the temperature coefficient and the temperature reference are set, the instrument's task is to measure the load resistance and the ambient temperature. After all the variables are determined, the 4176 automatically calculates the compensated resistance value.

Here is an example of the equation. Let us assume that we are measuring a copper wire, and we wish to know the resistance value at a temperature of 20°C. The temperature coefficient of copper is 0.003931Ω/°C.

If the load measures 1.0000Ω and the ambient temperature is 22.5°C:

$$R_C = \frac{1}{1 + 0.003931(22.5 - 20)} = 0.9903\Omega$$

The value of the load at 20°C would be 0.9903Ω.

Omni Compensator

The **4176** measures ambient temperature using an external sensor called the **Omni-TC**. This sensor is **not included** with the standard package and must be purchased separately. If the 4176 and Omni-TC are purchased at the same time, they are calibrated together for optimal accuracy.



Each instrument should have its **own dedicated Omni-TC sensor**. Sensors are **not interchangeable** between different ohmmeters without prior calibration. Additionally, calibration is required if the sensor is purchased separately. The calibration routine for TCM is described later in this chapter.

Enabling TCM Mode

To activate **Temperature Compensated Measurement (TCM)** mode:

- Press the **TCM** function key on the front panel.
- The **green TCM LED** on the front panel will illuminate to indicate that TCM is active.

If the **fault LED** is also lit, it indicates a problem with the Omni-TC connection. In this case, check that the Omni-TC sensor is properly connected to the front panel.

To deactivate TCM mode, press the **TCM** key again.

Temperature Compensator Setup

As described earlier, the 4176 requires a **temperature coefficient** and a **reference temperature** to calculate the compensated resistance value. The instrument's memory stores **six predefined configurations** that can be selected based on the material or application. Each configuration corresponds to specific coefficient and temperature reference values. Below is a table illustrating the typical values associated with each configuration, allowing the user to quickly select the appropriate setup for accurate temperature compensation.

Material	Configuration	Temperature Coefficient	Temperature Reference
Copper	CU20	3931 ppmΩ/°C	20°C
	CU25		25°C
Aluminum	AL20	4030 ppmΩ/°C	20°C
	AL25		25°C
Gold	AU20	3000 ppmΩ/°C	20°C
	AU25		25°C

The following procedure demonstrates how to select one of the predefined configurations or how to set up a customized configuration. This process only needs to be performed once; the selected or entered custom values will be saved and set as the default for future use whenever the TCM mode is activated.

Start by pressing **Func.** key.

Press any Function Key
or Press CLR to exit

Press (**TCM**) to start TCM Setup

Press [1]: TC SETUP
Press [2]: TC CAL
Press [CLR]: Exit

Press **1** to start TC Setup (TCS)

CU20[1] CU25[2] AL20[3]
AL25[4] AU20[5] AU25[6]
Customize[7] [SAVE]

Press the number **1-6** associated with the desired configurations or press **7** to input custom values.

Input Temp. Coefficient
____ PPM/°C
[CLR] [SAVE]

Using the numeric keys, enter the desired Temp. Coefficient. All 4 digits need to be entered. Value is in PPM/°C

Press **Save** to store as the new Temp. Coeff.

CLR clears the value in case of a mistake.

Input Reference Temp.
___.°C
[CLR] [SAVE]

Using the numeric keys, enter the desired Reference Temp. All 3 digits need to be entered. Value is in °C

Press **Save** to store as the new Ref. Temp.

CLR clears the value in case of a mistake.

Temperature Compensator Calibration

This procedure is used to match a 4176 with its Omni Compensator. Before beginning, verify that the instrument is located in a temperature-controlled environment to ensure accurate calibration and measurement.

Start by pressing **Func.** key.

Press any Function Key
or Press CLR to exit

Press (**TCM**) to start TCM Setup

Press [1]: TC SETUP
Press [2]: TC CAL
Press [CLR]: Exit

Press **2** to start TC Calibration (TCC)

Connect OMNI TC Sensor
and Press [ENTER]

As per the prompt, connect an Omni-TC to the front panel receptacle. It is recommended to wait a few minutes to allow the sensor time to settle to the current ambient temperature before continuing by pressing **Enter**.

Input Ambient Temp.
___.°C
and Press [SAVE]

Enter the current ambient temperature after checking with a thermometer. Temp. will be enter using 3 digits. No decimal point needs to be entered.

Press **SAVE** to continue.

CLR clears the value is they make a mistake.

TCM Cal. Complete
Press [CLR] to Exit

This concluded TCM calibration.

Once the calibration values are stored, press “**TCM**” and verify that the temperature displayed matches the ambient temperature. If the values do not match, repeat the procedure.

“HLC” – Hi-Lo Comparator Mode

The 4176 features a **Dual Limit Comparator (HLC)** that helps eliminate operator interpretation of readings, greatly reducing errors and fatigue while increasing testing efficiency. This mode is especially useful for applications such as receiving inspection of precision resistors by operators with minimal training, it streamlines quality control by providing immediate visual and automated feedback, reducing the need for manual interpretation.

Functionality:

The **Hi/Lo Comparator (HLC)** compares the measured value against user-defined limits. These limits can be set as either:

- **Min/Max** limits, or
- **Nominal \pm percentage** limits.

Based on the comparison, the system controls the **Buzzer**, **HLC LEDs**, and **HLC Relays** to indicate whether the load value is within or outside the specified limits.

This feature is **range-dependent**, meaning each measurement range can have its own specific limit setup. This allows for precise control and automation tailored to different measurement scales.

Example Application: Suppose you are inspecting 1 k Ω resistors with a tolerance of $\pm 0.1\%$. You would set the 4176 to the **2 k Ω range**, with the upper limit at **1.0010 k Ω** and the lower limit at **0.9990 k Ω** .



- If the measured resistance falls within these limits, the **green indicator** remains illuminated, indicating a within-tolerance condition.
- If either the **red indicator** (LO or HI) illuminates, the resistor exceeds the set limits and should be rejected.

To activate the Hi-Lo Comparator mode:

1. Select the appropriate measurement range for your load.
2. Press the “**HLC**” button.

the instrument will perform a **LED check sequence**: all three HLC LEDs will illuminate briefly. After the check, **only one** of the three LEDs will remain lit, indicating the current comparison status.

It is good practice to verify that the limits for the active range meet your specifications:

- Press “**VIEW + HLC**”.

The display will then show the **upper and lower limits** currently set for that range, allowing you to confirm or adjust as needed.

Min/Max HLC Setup

Start by pressing the **Func.** key.

Press any Function Key
or Press CLR to exit

Press (**HLC**) to start HLC Setup.

Select HLC Method
Press [1]: Min/Max
Press [2]: Nom. $\pm\%$

Press **1** for Min/Max

Enter Low Limit Value
____.____ Ω
[CLR] [SAVE]

Using the numeric keys, enter the desired low limit. All 5 digits need to be entered. Leading zeros if needed.

Press Save to store the value.

CLR clears the value in case of a mistake.

Enter High Limit Value
____.____ Ω
[CLR] [SAVE]

Using the numeric keys, enter the desired high limit. All 5 digits need to be entered. Leading zeros if needed.

Press [**Save**] to store the value.

CLR clears the value in case of a mistake.

HI Limit 101.00
LO Limit 99.00
[CLR] [SAVE]

The display will show the limits entered so that they can be reviewed. [**Save**] to confirm. [CLR] to start over.

BEEP Setting
[1]HILO [2]GO [3]HI
[4]LO [5]OFF

Choose the buzzer setting.

- [1] Beeps if the reading is HI or LO
- [2] Beeps if the reading is within limits
- [3] Beeps if the reading is HI
- [4] Beeps if the readings are LO
- [5] No HLC Beep

200 Ω Range HLC Setup
COMPLETE

Set up complete.

Nominal $\pm\%$ HLC Setup

Start by pressing the **Func.** key.

Press any Function Key
or Press CLR to exit

Press (**HLC**) to start HLC Setup

Select HLC Method
Press [1]: Min/Max
Press [2]: Nom. $\pm\%$

Press **2** for Nominal $\pm\%$

Press CLR to Exit

Enter Nominal Value
____.____ Ω
[CLR] [SAVE]

Using the numeric keys, enter the desired Nominal Value. All 5 digits need to be entered. Leading zeros if needed.

Press Save to store the value.

CLR clears the value in case of a mistake.

Enter +% Dev. Limit
+ ____. Ω
[CLR] [SAVE]

Using the numeric keys, enter the + deviation value. All 5 digits need to be entered. Leading zeros if needed.

Press Save to store the value.

CLR clears the value in case of a mistake.

Enter -% Dev. Limit
- ____. Ω
[CLR] [SAVE]

Using the numeric keys, enter the - deviation value. All 5 digits need to be entered. Leading zeros if needed.

Press Save to store the value.

CLR clears the value in case of a mistake.

Nominal: 100.00 Ω
+0.10% -0.10%
[CLR] [SAVE]

The display will show the limits entered so that they can be reviewed. [**Save**] to confirm. [CLR] to start over.

200 Ω Range HLC Setup
COMPLETE

Set up complete.

HLC Default Settings and Limits

Factory default values

Range	HLC Mode	Beep Mode	Low Limit	High Limit
20mΩ	Nom ± %	OFF	-0.10%	+0.10%
200mΩ	Nom ± %	OFF	-0.10%	+0.10%
2Ω	Nom ± %	OFF	-0.10%	+0.10%
20Ω	Nom ± %	OFF	-0.10%	+0.10%
200Ω	Nom ± %	OFF	-0.10%	+0.10%
2kΩ	Nom ± %	OFF	-0.10%	+0.10%
20kΩ	Nom ± %	OFF	-0.10%	+0.10%

HLC Relay Terminal (Optional)

The 4176 provides relay closure outputs that can be used to automate batch sorting, operate counters, sound alarms, or shut off processes. This is applicable for tolerancing items such as resistors, transformers, strain gauges, thermocouples, and thermistors.

The **HLC relay terminal** is wired internally to **three relays**, which activate only when the HLC mode is engaged. Based on the comparison result, one relay will have its contacts **closed**, while the other two relays will have their contacts **open**.

HI-LO Comparator Relay Pins

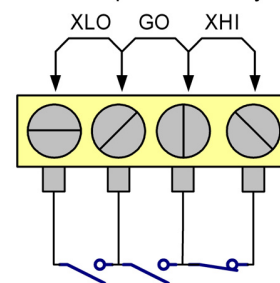

This "relay contact closure" feature allows for economical setup of automated sorting systems.

Connection Details:

- The HLC rear panel terminals are screw-type, suitable for connection to wires or spade lugs.
- The relays are rated at **100V, 100mA**.

HLC Truth Table

HLC State	HLC Result	XLO	GO	XHI
ON	$LL \leq \Omega \leq UL$	OPEN	CLOSED	OPEN
ON	$\Omega < LL$	CLOSED	OPEN	OPEN
ON	$\Omega > UL$	OPEN	OPEN	CLOSED
OFF	$LL \leq \Omega \leq UL$	OPEN	OPEN	OPEN
OFF	$\Omega < LL$	OPEN	OPEN	OPEN
OFF	$\Omega > UL$	OPEN	OPEN	OPEN

(Note: Ω is the measured load value; UL is the upper limit, LL is the lower limit set by the user.)

Display Brightness and Screen Saver Mode

The 4176 allows the user to customize the display brightness and activate a screen saver to extend the life of the display.

After **60 seconds** of no user interaction following a keypress, the instrument will automatically enter **screen saver mode**. During this mode, the display will **dim** or **turn off completely** until the next user input.

Brightness Settings:

The display brightness can be set to the following levels:

- **100%** (no dimming)
- **75%** (default setting)
- **50%**
- **25%**
- **0%** (screen turns off)

To set the brightness level press **Func.** then press the **View** key. Follow the prompts on the screen to select your preferred brightness level.

Other brightness percentages can also be configured via **serial interface commands** for advanced customization.

Run / Hold Feature

The **Run/Hold** key toggles the measurement display between **updating** continuously and **holding** the current reading.

- When in **Run mode**, the display updates automatically with new measurements.
- When **Hold mode** is activated, the current reading is **frozen** and will not update until the key is pressed again.

This feature allows the user to capture and record a specific measurement without it changing.

PeakHi/PeakLo Function

The PeakHi/PeakLo function allows the user to see the current reading alongside the maximum and minimum readings recorded while the function is on. This feature helps monitor how the resistance values change over time.

To activate or deactivate the Peak function, press the **PkHi/PkLo** button on the front panel.

When the Peak function is active, an indicator will show the display of the Peak Hi and Peak Lo values with the current measurement.

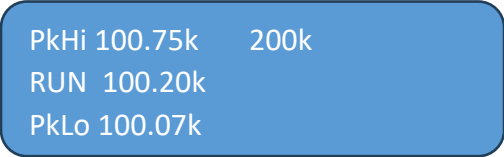

PkHi 100.75k 200k
RUN 100.20k
PkLo 100.07k

Additionally, a beeper will sound each time a new Peak Hi or Peak Lo is measured, providing an audible indication of the new peak values. These functions are also available while in Temperature Compensation Mode.

Note that enabling the Peak Hi and Peak Lo functions disables the auto range feature, ensuring stable and consistent measurement settings during use.

Send Function

The **Send** function allows the user to transmit a single measurement directly through one of the instrument's serial interfaces—**RS-232**, **USB**, or **Ethernet**—by simply pressing the **Send** key on the front panel.

Configuration Options:

The data can be sent in **three different formats**:

1. **Ohms:**
The measurement is formatted in ohms with the appropriate multiplier (e.g., 1.23k Ω).
2. **Screen:**
The value is formatted in ohms **without** any multiplier, as displayed on the screen.
3. **RDNG:**
The value is presented in **reduced engineering notation**, making it easier to interpret very large or small values.

The factory default setup is **OHMS**.

Send Function Setup

Start by pressing the **Func.** key.

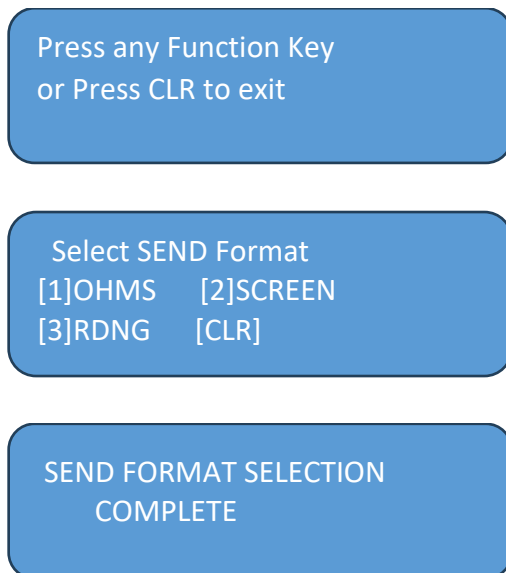

Press (**SEND**) to start SEND Setup

Press 1 for OHMS?

Press 2 for SCREEN?

Press 3 for RDNG?

Press CLR to Exit

Setup complete.

LOG Function

The **LOG** function enables continuous transmission of measurement data via one of the serial interfaces—**RS-232**, **USB**, or **Ethernet**. When activated, the instrument will **send ongoing measurement data** until the user presses the **Log** key again to stop.

To start or stop logging:

- Press the **Log** key on the front panel.

This feature is ideal for real-time data recording, remote monitoring, or trend analysis over extended periods.

Configuration Options:

1. **Ohms:**
The measurement value formatted in ohms with the appropriate multiplier (e.g., 1.23k Ω).
2. **Screen:**
The measurement value in ohms, displayed exactly as shown on the screen, without any multiplier.
3. **RDNG:**
The measurement in reduced engineering notation, making it easier to interpret very large or very small values.
4. **RDNG + RANGE:**
The measurement in reduced engineering notation combined with the currently selected range, providing additional context for the value.

The factory default setup is **OHMS**.

Log Delay Options:

The user can set the interval between data transmissions to control the data rate:

Option	Interval
1	50 milliseconds
2	100 milliseconds
3	200 milliseconds
4	250 milliseconds
5	500 milliseconds
6	1000 milliseconds (1 second)

LOG Function Setup

The following steps allow the user to configure the Log function type and delay.

Start by pressing the **Func.** key.

Press any Function Key
or Press CLR to exit

Press (LOG) to start LOG Setup

LOG Format: [1]OHMS
[2]SCREEN [3]RDNG
[4]RDNG+RANGE

Press the number associated with the desired format.

LOG Delay: (ms): [1]50 [2]100
[3]200 [4]250[5]500 [6]1000

Press the number associated with the desired delay.

LOG FORMAT SELECTION
COMPLETE

Setup complete.

Log/Send Interface Port Selection Function

The 4176 can have up to three interfaces. It is important to set the interface you wish to use for the front-panel Log and Send functions.

To select the desired interface, press Function, then Local.

Select UART Port [1] SERIAL
[2] USB [3] ETHERNET

Press the number associated with the desired port.

Note that the 4176 will revert to the interface that most recently received a command or query.

View Function

The **VIEW** function allows the user to check the current settings of various functions on the instrument.

To access the settings:

1. Press the **View** key.
2. Then press the specific function key related to the setting you want to review.

Available options include:

- **HLC:**
View the current **Hi/Lo Limit** settings.
- **TCM:**
View the **Temperature Coefficient** and **Temperature Reference** values.
- **LOG:**
View the **Data Format** and **Interval** settings for logging.
- **SEND:**
View the **Data Format** setting for the Send function.
- **LOCAL:**
View **Ethernet/IP** information and network settings.
- **CLR:**
Return the display to the **Idle** state, exiting the VIEW mode.

This feature provides quick access to important configuration parameters, ensuring proper setup.

Optional Features and Accessories

The 4176 Micro-Ohmmeter are shipped with a detachable power cord as standard equipment. This section lists several items that may be desirable for special applications.

Options

Ethernet Interface

The 4176 may be equipped with an optional Ethernet port located on the rear panel to enable network connectivity. This port allows the instrument to be integrated into local networks for remote monitoring, data logging, or control via standard Ethernet protocols. Details are available in the Remote Interface Chapter of this Manual.

HLC Relay Terminal

The HLC (High-Low Comparator) relay terminal is internally connected to three relays, which are active only when the HLC mode is enabled. The terminal can be used to implement an automated batch sorting system for components or products, operate counters, sound alarms, or shut off a process. For details see HLC Section of this manual.

Interlock Current Disable (ICD) Terminals

If the ICD option is installed on your 4176, the rear panel will feature a pair of terminals designated for this function. To enable the output current from the instrument, these terminals must be shorted together. When the terminals are open, the current output is disabled.

Accessories

Omni TC

To be able to use the TCM feature of the 4176, the user will need an Omni-TC temperature sensor. This item allows the ohmmeter to compensate for temperature variations when testing any material.



Option RX-3: Rack Mount Adapter

The 4176 Micro-Ohmmeter may be mounted in a standard 19" equipment rack using a set of optional rack ears. Option RX-3 comes with all the necessary hardware for installation and mounting.

Test Leads

This section details the different test lead sets and connectors available for use with the 4176 Micro-Ohmmeter. All cables and test leads are manufactured by Valhalla Scientific Inc. and tested before shipping.

Alligator Clip Type Leads

K: Kelvin Lead Set

"K" is a shielded, 4-wire Kelvin cable set, 48 inches in length terminated in gold plated alligator clips (*KCS*).

Option "K" is the recommended general purpose lead set for most applications. *Figure 6*.



Figure 6 - K: Kelvin 4-Wire Lead Set

KCS: Gold-Plated Clips

"KCS" are gold-plated alligator clips used on the "K" lead set for 4-wire measurements of smaller components and leads. Clips open to 1/2 inch and accommodate test currents of up to 10A.

C: Banana-to-Clip Cable

"C" is a 48" general purpose shielded lead set terminated on one end in dual banana plugs and on the other end in red and black alligator clips.

KK: Heavy-Duty Lead Set

"KK" is a 4-wire Kelvin cable set, 48-inches in length terminated in heavy-duty gold-plated clamps. *Figure 7*.



Figure 7 - KK: Kelvin 4-Wire Lead Set

JAWS: Gold-Plated Clamps

"JAWS" are gold-plated heavy-duty clamps. Clamps open 2 inches for connection to large motors, bushings, etc.

Needle Type Probes

MP-1: Kelvin Micro-Probes

"MP-1" is a 48-inch shielded 4-wire Kelvin cable set with a 1A test current capacity employing a set of Kelvin Micro-Probes. The probes are equipped with spring-loaded stainless-steel tips with 0.05" spacing.

MP-2: Kelvin Mini-Probes

"MP-2" is a 48-inch shielded 4-wire Kelvin cable set with a 1A test current capacity employing a set of Kelvin Mini-Probes. The probes are equipped with spring-loaded stainless-steel tips with 0.18" spacing.

MP-S: Single Pointed Probe Set

"MP-S" is a 48-inch shielded cable set with a 1A test current capacity employing a set of single pointed handheld pencil type probes. (2 wires to each point).

Surface Probes

MP-4: Surface Probes

These probes permit rapid, repeatable bonding testing on a variety of screened or flat surfaces. Test current is evenly distributed through the probe base while sensing is accomplished via a spring-loaded center contact. The target area is 1-inch in diameter. *Fig. 8*

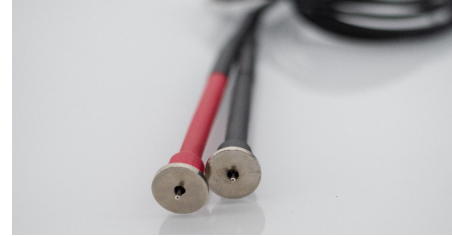

Figure 8 - MP-4 Surface Probe

MP-5: Surface Probes

These probes permit rapid, repeatable bonding testing on a variety of screened or flat surfaces. Test current is evenly distributed through the probe base while sensing is accomplished via a spring-loaded center contact. The target area is 1/2 inch in diameter.

Other Lead Sets

BBL: Banana-to-Banana Cable

"BBL" is a 48" shielded cable terminated on both ends in dual stacking banana plugs. This cable may be used for voltage and current connections to the ohmmeter.

SL-48: Low Thermal Leads

"SL-48" is a 48" shielded lead set terminated in gold-plated spade lugs. This lead set is designed to eliminate problems caused by thermal EMF's and is rated for the maximum output current of 1A.

Remote Interface

This chapter describes how to operate the 4176 remotely via its serial interfaces, including RS-232, USB, and Ethernet. Remote operation enables integration with external systems for automated control, data logging, and monitoring.

RS-232 Interface

Capabilities

The RS-232 interface provides a point-to-point connection between the 4176 and an external device such as a computer. Once configured, you can control the instrument and retrieve data through this interface.

Communication Parameters

Set the RS-232 parameters on both the 4176 and the external device to ensure proper communication:

- **Baud rate:** 115200 baud
- **Parity:** None
- **Data bits:** 8 bits
- **Stop bits:** 1 stop bit
- **Flow control:** None

Notes for Installation

- The 4176 uses a **9-pin D-type female connector** on the rear panel (see Table 3 below for pin assignments).
- Many devices require a constant high signal (e.g., RTS or DTR) on certain input pins.
- Connect the **signal ground** of the external device to the 4176's signal ground.
- Connect the **chassis ground** of both devices.
- Use cables no longer than **15 meters** to prevent signal degradation.
- Ensure that the baud rate and other parameters match between the device and the PC.

	Pin #	Pin Function
	1, 4, 6, 7, 8, 9	Not Connected
	2	Receive Data (RxD) (input)
	3	Transmit Data (TxD) (output)
	5	Signal Ground (GND)

Table 3 - RS-232 Connector Pin Configuration

Connecting to a Computer

1. Connect one end of an RS-232 cable to the computer's serial port.
2. Connect the other end to the 4176's RS-232 port.
3. Power on the 4176.
4. Power on the computer.

Input and Output Queues

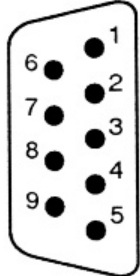
The RS-232 interface uses:

- **Input queue:** 64 bytes
- **Output queue:** 128 bytes

USB Interface

The 4176 is equipped with a standard USB Type B receptacle located on the rear panel. This interface allows for easy connection to a computer for control and data transfer.

Compatibility and Commands

The USB interface supports the same command set as the RS-232 interface. All commands, query formats, and syntax are identical, making the transition between interfaces seamless.

Connection and Setup

1. Connect a USB Type B cable from the 4176 to the computer's USB port.
2. Power on the 4176; the device will be recognized as a COM port by most operating systems.
3. Use your terminal or control software to communicate with the instrument via the assigned COM port.

Software Drivers

Ensure that the appropriate drivers are installed if required. The command set remains the same as outlined for RS-232, simplifying software development and integration.

Ethernet Interface (Optional)

The 4176 can be optionally equipped with an **Ethernet** interface, enabling remote control and data transfer over a local network or the internet. This provides greater flexibility for automation, remote monitoring, and integration into larger systems.

Overview

The Ethernet interface supports standard TCP/IP communication protocols and is configured via the instrument's network settings. Once connected, the 4176 can be controlled using the same command set as the RS-232 and USB interfaces, ensuring seamless integration.

Hardware Connection

1. Connect an Ethernet cable from the 4176's Ethernet port (RJ45 connector) to your network switch, router, or PC directly (using a crossover cable if required).
2. Power on the 4176.

Default Configuration

By default, the Ethernet interface is configured for **Static IP operation** with the following settings:

- **IP Address:** 192.168.1.50
- **Mode:** Static IP

Changing Network Configuration

All Ethernet configuration changes are performed via the **serial or USB interface**.

Set Configuration Mode

- Enable DHCP:
eth dhcp
- Set Static IP mode:
eth stat

Set IP Address (Static Mode Only)

```
eth stat <ip_address>
```

Example: eth stat 192.168.1.100

Set Subnet Mask

```
eth mask <subnet_mask>
```

Example: eth mask 255.255.255.0

Set Gateway

```
eth gw <gateway>
```

Example: eth gw 192.168.1.1

Obtaining the IP Address

To view the IP address and Port setting on the 4176, Press **View** followed by the **Local** Key. The screen will display the following:

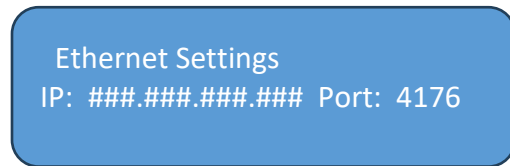

Communication and Command Set

The Ethernet interface supports the same command set and syntax as the RS-232 and USB interfaces. Commands are sent as plain text over TCP/IP, terminated with CR/LF, and responses follow the same format.

Establishing a Connection

1. Use a TCP/IP socket connection to connect to the instrument's IP address and port (default port is typically 4176 but verify your device settings).
2. Once connected, the instrument will accept commands in the same format as RS-232/USB.

Note: The command syntax, data formats, and responses are identical to those used in the RS-232 and USB interfaces, simplifying software development and remote operation.

Commands

As previously stated, the following list of commands are valid across all 3 interface formats (RS-232, USB and Ethernet).

Commands and Syntax

- Commands may be terminated with **LF**, **CR**, or **CR/LF**.
- After executing a command, the instrument appends a **CR/LF** to responses.

Entering Commands

- Commands are not case-sensitive.
- One (and only one) space must separate command headers from parameters.

Verifying Connection

To test the connection, send an identification query:

*idn?

The 4176 should respond with: **VALHALLA SCIENTIFIC 4176, 4.01A** (depending on firmware revision)

If no response is received, resend the command. If no response is received, verify power and cable connections.

Details of Command Reference

Each command described in this section will include a detailed explanation, example syntax, and the expected response or query result.

Remote mode is activated when the instrument receives a **valid printable character** via the communication interface. To exit remote mode, use the **LOCAL** front panel key or send the **LOCAL** command.

Alphabetical Commands & Queries Summary Table

Comm/ Query	Type	Syntax	Returns	Notes	Detail on page
*IDN	Q	*IDN?	ID string: Manufacturer, Model, Firmware	Alternate syntax: IDN?, *IDN, IDN	45
Bright	C	Bright <0-15>	<crLf>	Sets display brightness (0=OFF ... 15=100%)	49
Bright?	Q	Bright?	Brightness value (0-15)	Returns brightness percentage	49
CStat?	Q	CStat?	"0" (No Fault) / "1" (Fault)	TCM sensor status	58
Eth?	Q	Eth?	Ethernet IP (x.x.x.x)	Returns 0.0.0.0 if no Ethernet	49
HLC	C	HLC <ON/OFF>	<crLf>	Enable/disable Hi-Lo Comparator	54
HLC?	Q	HLC?	"ON" or "OFF"	Returns state	54
HLCHI	C	HLCHI <value>	<crLf> or "Invalid Value"	Sets comparator High limit (range dependent)	54
HLCHI?	Q	HLCHI?	Current High limit	Returns numeric value	55
HLCL0	C	HLCL0 <value>	<crLf> or "Invalid Value"	Sets comparator Low limit (range dependent)	55
HLCL0?	Q	HLCL0?	Current Low limit	Returns numeric value	55
HLCS?	Q	HLCS?	"HI" / "LO" / "GO" / "OFF"	Comparator status	54
LOCAL	C	LOCAL	<crLf>	Sets device to Local mode; keypad active	45
LOGOFF	C	LOGOFF	<crLf>	Stops continuous logging	52
LOGON	C	LOGON <0-5>	Depends on mode	Starts continuous logging; response depends on value	52
LogSpeed	C	LogSpeed <1-6>	<crLf>	Sets log interval (1=50ms ... 6=1000ms)	53
LogSpeed?	Q	LogSpeed?	Current log speed (1-6)	Returns timing code	53
OHMS?	Q	OHMS?	Resistance in ohms with multiplier	Range formatted; no leading zeros	51
Port	C	Port <xx>	<crLf>	Sets Ethernet port (default=4176)	49
Port?	Q	Port?	Current port	Default = 4176	50
RANGE	C	Range <0-7 or A>	<crLf>	Selects measurement range; Default=A	46
RANGE?	Q	Range?	Current range (0-7, A)	Returns selected range	47
RDNG?	Q	RDNG?	Engineering notation value	e.g., 4.998e-3, 1.0000e+1	52

Comm/ Query	Type	Syntax	Returns	Notes	Detail on page
RESET	C	RESET	Display shows "RESETTING"	Soft reset, restores defaults	46
RSTDFLT	C	RSTDFLT	<crLf>	Resets stored setup to factory defaults	48
SCREEN?	Q	SCREEN?	Display data without multipliers	Raw front panel string	51
Serial?	Q	Serial?	Serial number string	e.g., "70-241001"	45
Store	C	Store	<crLf>	Saves current setup for power-up	47
Stored?	Q	Stored?	Encoded 5-digit string	Encodes Range, Auto, TCM, HLC, PkHiLo	48
Temp?	Q	Temp?	Temperature in °C	Valid only if TCM=ON	59
TCoeff	C	TCoeff <1-9999>	<crLf> or error	Sets temperature coefficient (ppm/°C)	57
TCoeff?	Q	TCoeff?	Current coefficient	Returns numeric value	57
TCM	C	TCM <ON/OFF>	<crLf>	Enable/disable Temperature Compensation	56
TCM?	Q	TCM?	"ON" or "OFF"	Returns state	56
TCS	C	TCS <0-6>	<crLf>	Selects preset configuration (CU20, AL25, etc.)	56
TCS?	Q	TCS?	Config number (0-6)	0=Custom, use TCoeff? / TRef?	57
TRef	C	TRef <0-50.0>	<crLf>	Sets reference temperature (°C)	58
TRef?	Q	TRef?	Current reference temperature	Returns numeric value	58
UCOhms?	Q	UCOhms?	Uncompensated resistance	Valid only if TCM=ON	59

Table 4 - Command & Query Summary Table

System Commands and Queries

IDN*QUERY**

Returns serial identification string from non-volatile.

Syntax: idn?<crLf>

Returns: ID string "VALHALLA SCIENTIFIC 4176,4.01A"

Example: *Idn?<crLf>
"VALHALLA SCIENTIFIC 4176,4.01A"<crLf>

ID_STRING : "VALHALLA SCIENTIFIC"

MODEL : "4176"

FIRMWARE VERSION : "4.01A"

Note Alternate Syntax: IDN, IDN?

Serial?**QUERY**

Returns the Serial Number of the device.

Syntax: Serial?<crLf>

Returns: Serial Number string

Example: Serial?<crLf>

Returns: "70-241001"

LOCAL**COMMAND**

Returns meter to local mode, remote LED off, Keypad functions.

Syntax: LOCAL<crLf>

Returns: <crLf>

Power-on default = LOCAL mode

Remote mode is activated when the meter receives a valid character or command (anything other than <crLf>). In remote mode, all keypad keys are disabled, so no key beeps occur, except for the LOCAL key. Pressing

the LOCAL key in remote mode will turn off the REMOTE LED and switch the device back to local mode, enabling keypad operation.

RESET	COMMAND
--------------	----------------

Executes a soft reset of the device.

Syntax: RESET<cr><lf>

Returns: Front panel display shows soft reset initiation. "RESETTING" is displayed flashing while all system configurations are returned to power up default.

RANGE	COMMAND
--------------	----------------

Selects a measurement range.

Syntax: Range <range number><cr><lf>

Range number = 0 - 7

0 = RANGE_OFF (SAFE MODE)

1 = R20mOHM

2 = R200mOHM

3 = R2_OHM

4 = R20_OHM

5 = R200_OHM

6 = R2K_OHM

7 = R20K_OHM

A = RANGE_AUTO

Power-on default = A

NOTE: RANGE_OFF turns off all Range Relays for no current is sourced out of the device. Range value in top right window is set to SAFE.

RANGE	QUERY
--------------	--------------

Returns the selected range.

Syntax: RANGE?<crLf>

Returns: Range number = 0 - 7

0 = RANGE_OFF (SAFE MODE)

1 = R20mOHM

2 = R200mOHM

3 = R2_OHM

4 = R20_OHM

5 = R200_OHM

6 = R2K_OHM

7 = R20K_OHM

A = RANGE_AUTO

Power-on default = A

STORE SETUP	COMMAND
--------------------	----------------

Allows the user to store range, TCM ON/OFF, HLC ON/OFF, PkHiLo On/Off settings. At power up the unit will turn on as range and functions as stored.

Syntax: Store<crLf>

Returns: <crLf>

Default values are:

Range: 20k

Auto: ON

TCM: OFF

HLC: OFF

PkHiLo: OFF

STORED SETUP **QUERY**

Returns stored power up setting as a string.

Syntax: Stored?<crLf>

Returns: xxxxxx

String digits represent:

1. Range: Value can be 0-7
2. AUTO: Value is 0 for off and 1 for on
3. TCM: Value is 0 for off and 1 for on
4. HLC: Value is 0 for off and 1 for on
5. PkHiLo: Value is 0 for off and 1 for on

Example: Stored?<crLf>

Returns: "60100"

The device is set to power up in the 2k range. Auto range is off, TCM is on, HLC is off and PkHiLo is off.

RESET SETUP **COMMAND**

Allows the user to reset store range, TCM ON/OFF, HLC ON/OFF, PkHiLo On/Off settings to the factory defaults.

Syntax: RSTDFLT<crLf>

Returns: <crLf>

Default values are:

- Range: 20k
Auto: ON
TCM: OFF
HLC: OFF
PkHiLo: OFF

DISPLAY BRIGHTNESS COMMAND

Sets the resting display brightness.

Syntax: Bright <xx><crLf>

Brightness number = 0 - 15

0 = OFF	4 ~ 27%	8 ~ 53%	12~ 80%
1 ~ 7%	5 ~ 33%	9 ~ 60%	13~ 87%
2 ~ 13%	6 ~ 40%	10~ 67%	14~ 93%
3 ~ 20%	7 ~ 47%	11~ 73%	15~ 100%

DISPLAY BRIGHTNESS QUERY

Returns the selected resting display brightness.

Syntax: Bright?<crLf>

Returns: Range number = 0 - 15

0 = OFF	4 ~ 27%	8 ~ 53%	12~ 80%
1 ~ 7%	5 ~ 33%	9 ~ 60%	13~ 87%
2 ~ 13%	6 ~ 40%	10~ 67%	14~ 93%
3 ~ 20%	7 ~ 47%	11~ 73%	15~ 100%

ETHERNET IP QUERY

Returns Ethernet IP address.

Syntax: Eth?<crLf>

Returns: x.x.x.x

Note: If the Ethernet option is not installed, or the device is not connected to a network, the query will return 0.0.0.0

ETHERNET PORT COMMAND

This command allows the user to change the ethernet port setting.

Syntax: port <xx><crLf>

Returns: <crLf>

Default value is 4176.

ETHERNET PORT QUERY

Returns Ethernet Port setting.

Syntax: Port?<crLf>

Returns: 4176

Default value is 4176.

Measurement Commands and Queries

OHMS?**QUERY**

Responds with the front panel reading formatted in ohms with multiplier.
No leading zeros.

Syntax: OHMS?<crLf>

Returns: <Display data in Ohms with multiplier><crLf>

Example for a 1.1m ohm reading on:

```
20mΩ Range:      1.100m
200mΩ Range:     1.10m
2Ω Range:        0.0011
```

Example for a 1.1 ohm reading on:

```
2Ω Range:        1.1000
20Ω Range:       1.100
200Ω Range:      1.10
2kΩ Range:       0.0011k
```

SCREEN?**QUERY**

Responds with reading from the front panel display. The Ohms omega (Ω), milli (m Ω) and kilo (k Ω) characters are removed during this formatting.

Syntax: SCREEN?<crLf>

Returns: <Display data without multiplier><crLf>

Example for a 1.1m ohm reading on:

```
20mΩ Range:      01.100
200mΩ Range:     001.10
2Ω Range:        0.0011
```

Example for a 1.1 ohm reading on:

```
2Ω Range:        1.1000
20Ω Range:       01.100
200Ω Range:      001.10
2kΩ Range:       0.0011
```

LOG SPEED**COMMAND**

Sets the speed of the LOG Functions.

Syntax: LogSpeed <speed number><crLf>

Range number = 1 - 6

- 1 = 50msec
- 2 = 100msec
- 3 = 200msec
- 4 = 250msec
- 5 = 500msec
- 6 = 1000msec

LOG SPEED**QUERY**

Returns the selected Log Speed.

Syntax: LogSpeed?<crLf>

Returns: Range number = 1 - 6

- 1 = 50msec
- 2 = 100msec
- 3 = 200msec
- 4 = 250msec
- 5 = 500msec
- 6 = 1000msec

HLC Commands and Queries

HLC	COMMAND
-----	---------

Selects HLC mode on or off

Syntax: HLC <ON or OFF><crLf>

HLC	QUERY
-----	-------

Responds with HLC mode on or off

Syntax: HLC?<crLf>

Returns: <"ON" or "OFF">

HLC STATUS	QUERY
------------	-------

Responds with status of the comparison. HI, LO, or GO

Syntax: HLCS?<crLf>

Returns: <"HI" or "LO" or "GO" or "OFF">

HLCHI	COMMAND
-------	---------

Sets the Hi-Lo Comparator High Limit for current range.

Syntax: HLCHI <value><crLf>

Value is only valid if entered properly. See acceptable values/range

Range	Min	Max
R20mOHM	00.001	19.999
R200mOHM	000.01	299.99
R2_OHM	0.0001	2.9999
R20_OHM	00.001	29.999
R200_OHM	000.01	299.99
R2K_OHM	0.0001	2.9999
R20K_OHM	00.001	29.999

Returns "Invalid Value" if outside specified values.

Note: Command not valid while in Auto Range. Return "Invalid Command"

TCM Commands and Queries

TCM	COMMAND
-----	---------

Selects TCM mode on or off

Syntax: TCM <ON or OFF><crLf>

TCM	QUERY
-----	-------

Responds with TCM mode on or off

Syntax: TCM?<crLf>

Example: TCM?<crLf>

Returns: <"ON" or "OFF">

TCS	COMMAND
-----	---------

Selects Temperature Compensation Configuration Setting.

Syntax: TCS <Value><crLf>

Returns: <crLf>

Example: TCS 1<crLf>

TCS Preset Configurations

=====

1 = CU20

2 = CU25

3 = AL20

4 = AL25

5 = AU20

6 = AU25

TCS	QUERY
------------	--------------

Returns the selected range.

Syntax: TCS?<crLf>

Returns: Configuration number = 0 - 6

1 = CU20

2 = CU25

3 = AL20

4 = AL25

5 = AU20

6 = AU25

0 = Custom Values

Note: If the Query returns "0", use TCoeff?, and TRef?, to find Temperature coefficient and reference.

TEMP. COEFFICIENT	COMMAND
--------------------------	----------------

Sets the Temperature Coefficient used during TCM. Value must be entered in PPM/°C.

Syntax: TCoeff <value><crLf>

Returns: <crLf>

Value is only valid if entered properly.

Acceptable values

1 9999

Return "Invalid Value" if outside specified values.

TEMP. COEFFICIENT	QUERY
--------------------------	--------------

Returns the Temperature Coefficient used during TCM.

Syntax: TCoeff?<crLf>

Returns: <Selected Temp. Coeff.>

Example: TCoeff?<crLf>

Returns: <3456>

TEMP. REFERENCE	COMMAND
-----------------	---------

Sets the Temperature Reference used during TCM. Value must be entered in °C.

Syntax: TRef <value><crLf>

Returns: <crLf>

Value is only valid if entered properly.

Acceptable values

Min	Max
0	50.0

Return "Invalid Value" if outside specified values.

TEMP. REFERENCE	QUERY
-----------------	-------

Returns the Temperature Coefficient used during TCM.

Syntax: TRef?<crLf>

Returns: <Selected Temp. Reference>

Example: TRef?<crLf>

Returns: <20.0>

SENSOR STATUS	QUERY
---------------	-------

Responds with TCM Sensor Status. Fault or No Fault.

Syntax: CStat?<crLf>

Example: CStat?<crLf>

Returns: <"0" or "1">

0 = No Fault

1 = Fault

Keypad Commands

KEY	COMMAND
-----	---------

Presses a key from the interface, use for macros when the command you desire is not listed here.

The remote key macro command was developed so our customers can literally perform any action from the remote available to the key press enthusiast.

We will note the following to the user: This capability is not without restrictions. Illegal key sequences may get the machine in a menu you do not expect or cause the meter to not process properly the keys you send. Key presses are human interface and therefore not buffered. Because of this key delays may be necessary as sending keys too quickly may lose keys.

Syntax: KEY <key number>

Returns: <crLf> (only after the key has been processed)

Key number = 0 - 23

0	= No_Key	12	= Key_#5_Send
1	= Key_Rng1 (20m Ω)	13	= Key_#6_TCM
2	= Key_Rng2 (200m Ω)	14	= Key_#7_AutoRange
3	= Key_Rng3 (2 Ω)	15	= Key_#8_Cal
4	= Key_Rng4 (20 Ω)	16	= Key_#9_Log
5	= Key_Rng5 (200 Ω)	17	= Key_#0_View
6	= Key_Rng6 (2k Ω)	18	= Key_Local
7	= Key_Rng7 (2k Ω)	19	= Key_Clear
8	= Key_#1_PkHiLo	20	= Key_Function
9	= Key_#2_HLC	21	= Key_Save
10	= Key_#3_Store	22	= Key_Reset
11	= Key_#4_Run/Hold	23	= Key_Enter

General Maintenance and Calibration

General

This chapter provides information on general maintenance and the procedure for calibrating the Model 4176 μ -Ohmmeter.

To ensure continued accuracy, your model 4176 should be calibrated on a routine basis. A **12-month interval** is recommended.

Before performing the calibration procedure, the ohmmeter must be allowed to **warm up for at least 30 minutes** at a stable ambient temperature with all covers in place.

Required Test Equipment

The following equipment is required to perform calibration of the Model 4176:

1. **Precision Resistors** ($\pm 0.005\%$ tolerance)
 - 0.01 Ω
 - 0.1 Ω
 - 1 Ω
 - 10 Ω
 - 100 Ω
 - 1 k Ω
 - 10 k Ω
2. **DC Voltage Standard**
 - Capable of providing outputs of 0, 5mV, 10mV, 19mV, 50mV, 100mV, and 270mV
 - Additionally, if calibrating the temperature compensation circuit: 200mV and 300mV
3. **Four-Wire Test Lead Set**
4. **Precision Digital Voltmeter (DVM)**

Pre-Calibration Procedure

Calibration adjustments are accessed by removing the **top cover** of the instrument.

- Leave the cover in place as much as possible.
- After each adjustment, replace the cover and allow the instrument to **stabilize** before proceeding.

Warning — Electrical Hazard

Dangerous AC line voltages are present inside the instrument when the cover is removed. Use extreme caution when making adjustments and avoid contact with exposed high-voltage areas.

Calibration Procedure

The standard calibration consists of 2 parts: sense calibration, and source calibration. The sense calibration is cover-on and automated; the instrument will prompt the user throughout the steps. The source calibration is performed by adjusting potentiometers located on the 4176 main board. Both calibrations must be performed for a complete calibration of the 4176.

Sense Calibration

Press any Function Key
or Press CLR to exit

Press [CAL] to select calibration type.

Press [CAL]: Sense Cal
Press [TCM]: TCM Cal
Press [CLR]: Exit

Press [CAL] to start Sense Calibration.

Pressing [CLR] at any point during calibration, will exit the routine.

Sens Cal, 20mV Range
Set Cal input to: 0mV
[CLR] [SAVE]

Connect the voltage source to the Sense terminals of the 4176. Place a jumper from Sense LO to Source HI terminals.

Apply 0mV and press [SAVE]

Sens Cal, 20mV Range
Set Cal input to: 5mV
[CLR] [SAVE]

When prompted, apply 5mV and press [SAVE]

Repeat this step as prompted applying:

10mV, 19mV, 0V, 50mV, 100mV, and 270mV.

Disconnect the voltage source from the Sense Terminals.

Sense Cal. Complete
Press [ENTER] or
Press [TCM] for TCM Cal

Press [ENTER] to skip TCM calibration, or Press [TCM] to continue calibrating the temperature compensation ADC.

TCM Calibration is only required if a temperature sensor (Omni-TC) is used. You will not be able to perform the following steps without a sensor.

Source Calibration

1. **Short SENSE HI and SENSE LO** terminals using a jumper.
2. Connect the **DVM** to the main board as follows: DVM negative input to **TP9** DVM positive input to **TP10**.
3. **Adjust RV1** for a DVM reading of **-1.0000V**.
4. Remove the DVM connection and the jumper.
5. Select the **.2Ω range**.
6. Connect the 4176 to a **.1Ω** standard resistor.
7. **Adjust RV2** for a display reading equal to the value of the load.
8. Select the **2Ω range**.
9. Connect the 4176 to a **1Ω** standard resistor.
10. **Adjust RV3** for a display reading equal to the value of the load.
11. Select the **20Ω range**.
12. Connect the 4176 to a **10Ω** standard resistor.
13. **Adjust RV4** for a display reading equal to the value of the load.
14. Select the **200Ω range**.
15. Connect the 4176 to a **100Ω** standard resistor.
16. **Adjust RV5** for a display reading equal to the value of the load.
17. Select the **2kΩ range**.
18. Connect the 4176 to a **1kΩ** standard resistor.
19. **Adjust RV6** for a display reading equal to the value of the load.
20. Select the **20kΩ range**.
21. Connect the 4176 to a **10kΩ** standard resistor.
22. **Adjust RV7** for a display reading equal to the value of the load.
23. Connect the 4176 to a **10mΩ** standard resistor.
24. Select the **20mΩ range**.
25. Verify that the reading is within 0.002mΩ from the nominal value.⁶
26. **End of Source Calibration.**

⁶ If the 20mΩ range value exceeds the specified tolerance, please contact Valhalla Scientific Technical support.

Optional TCM Sense Calibration

Temp Cal,
Set TP1 – TP2 to: 0mV
[CLR] [SAVE]

Temp Cal,
Set TP1 – TP2 to: 100mV
[CLR] [SAVE]

Disconnect from TP1 TP2
Connect OMNI TC Sensor
and Press [SAVE]

Input Ambient Temp.
__._ °C
and Press [SAVE]

TCM Cal Complete
Press [ENTER]

Connect the voltage source to TP1(+) and TP2(-) located on the Controller board (near input terminals).

Short Sense HI, Sense LO and Source Hi Terminals. **If connected, remove the Omni TC from the 4176.**

Apply 0mV and Press [SAVE]

When prompted, apply 100mV and press [SAVE].

Repeat this step as prompted applying 200mV and 300mV.

When prompted, disconnect the voltage source from TP1-TP2. Connect the Omni TC Sensor to the front panel receptacle.

Allow **5 minutes** for the sensor to reach ambient temperature and press [SAVE]

Verify the current ambient temperature.

Enter the value in °C and press [SAVE]

Calibration is complete. Press [ENTER] to return to measurement mode.

Special Procedures

Noisy Readings

Noisy readings are most often caused by poor connections at either the input terminals or the test load.

If excessive noise is observed, verify these connections first.

Inductive Loads

When measuring highly inductive loads (such as large transformers), noisy readings may occur. This results from the high impedance to line voltage exhibited by the load, which increases susceptibility to noise pickup. Using fully shielded cables can greatly reduce this effect.

Additionally, transformer tests may benefit from short-circuiting unused windings during measurement. This reduces the inductance of the winding under test, shortens settling time, and prevents the unused windings from generating hazardous voltages when the ohmmeter is connected or disconnected.

For repair and calibration services, call 800-548-9806 or visit valhallascientific.com.
Email support available at support@valhallascientific.com



4176 Programmable Digital micro-Ohmmeter User Manual
Revision 70-3 (2026)
Copyright © 2026 Valhalla Scientific, Inc. All rights reserved

