



# 4314KV-4314KVS

## Rugged Digital Igniter Tester

Operations Manual





## VALHALLA SCIENTIFIC INC. CERTIFICATION

Valhalla Scientific, Inc. certifies that this instrument was thoroughly tested and inspected and found to meet published specifications when shipped from the factory. Valhalla Scientific, Inc. further certifies that its calibration measurements are traceable to the Nation Institute of Standards and Technology to the extent allowed by NIST's calibration facility.

Due to continuing product refinement and due to possible parts manufacturer changes, Valhalla Scientific, Inc. reserve the rights to change any or all specifications without notice.

## VALHALLA SCIENTIFIC INC. WARRANTY STATEMENT

The warranty period for this instrument is stated on your invoice and packing list. Please refer to these to determine appropriate warranty dates.

We will repair the instrument during the warranty period provided it is returned to Valhalla Scientific, Inc. freight prepaid. No other warranty is expressed or implied.

Valhalla Scientific, Inc. is not liable for consequential damages.

Permission and a Return Material Authorization number (RMA) must be obtained directly from the factory for warranty repairs. No liability will be accepted if returned without such permission.

Due to continuing product refinement and due to possible parts manufacturer change, Valhalla Scientific reserves the right to change any or all specifications without notice.

4314KV/KVS Digital Igniter Tester User Manual  
Revision # 1 Edition 1 (2017)  
Copyright © 2017 Valhalla Scientific, Inc. All rights reserved



## WARNINGS

The following general safety precautions must be observed during all phases of operation, service, and repair of this product. Failure to comply with these precautions or with specific warnings elsewhere in this manual violates safety standards of design, manufacture, and intended use of the product. Valhalla Scientific assumes no liability for the customer's failure to comply with these requirements.

For continued protection, replace the line fuse(s) only with fuse(s) of the same voltage and current rating and type. DO NOT use repaired fuses or short-circuited fuse holders.

Keep away from live circuits: Operating personnel must not remove equipment covers or shields. Procedures involving the removal of covers or shields are for use service trained personnel only. Under certain conditions, dangerous voltage may exist even with the equipment switched off. To avoid dangerous electrical shock, DO NOT perform procedures involving cover or shield removal unless you are qualified to do so.

DO NOT operate damaged equipment: Whenever it is possible that the safety protection features built into this product have been impaired, either through physical damage, excessive moisture, or any reason, REMOVE POWER and do not use the product until safe operation can be verified by service-trained personnel. If necessary, return the product to Valhalla Scientific for service and repair to ensure that safety features are maintained.

DO NOT substitute parts or modify equipment: Because of the danger of introducing additional hazards, do not install substitute parts or perform any unauthorized modification to the product. Return the product to Valhalla Scientific for service and repair to ensure that safety features are maintained.

Permanent wiring of hazardous voltage or sources capable of delivering greater than 150VA should be labeled, fused, or in some other way protected against accidental bridging or equipment failure.

DO NOT leave measurement terminals energized when not in use.

## Table of Contents

Chapter 1 – General Information.....	1
Instrument Description.....	1
Safety Considerations.....	1
Instrument Identification.....	1
Chapter 2 – Unpacking and Installing.....	2
Inspection.....	2
Power Requirements.....	2
Installation.....	2
Chapter 3 – Specifications.....	3
Range/Resolution/Test Current/Failsafe Current.....	3
Accuracy.....	3
Temperature.....	4
General Specifications.....	4
Physical Specifications.....	4
Chapter 4 – Optional Equipment.....	5
Available Options.....	5
Option A2: Battery Charger.....	5
Replacement Batteries.....	5
AC-115: Continuous Isolated AC Power.....	5
Test Leads.....	5
Option K-174: 4-Wire Kelvin Lead Set (RG174 coaxial cable).....	5
Option K: 4-Wire Kelvin Lead Set.....	5
Option MP-S: Single Probe Lead Set.....	5
Option MP-1: Kelvin Micro-Probes.....	5
Option MP-2: Kelvin Mini-Probes.....	6
Option MP-3: Kelvin Micro-Probes.....	6
Option MP-4/MP-5: Surface Probes.....	6
Option KK: 4-Wire Kelvin Lead Set.....	6
Option C: Banana-to-Clip Cable.....	6
Option BBL: Banana-to-Banana Cable.....	6
Option KCS: Kelvin Clips.....	6

Option JAWS: Heavy-Duty Clips .....	6
Chapter 5 – Features and Operations.....	7
General.....	7
Front Panel.....	7
ON/OFF Button .....	7
Range Selection Knob .....	7
Fuse Holder .....	7
Charging Jack.....	7
Fail Safe Button (model 4314KVS only) .....	7
Connections .....	10
4-Wire Resistance Measurement .....	10
Displays .....	11
Ohms Display and Multiplier LEDs .....	11
Interpreting the Display .....	11
Current Display and Multiplier LEDs (KVS models only) .....	11
Fail-Safe Operation .....	12
Fail-Safe Test (model 4314KVS only) .....	12
Low Battery Indicator.....	13
Standby Mode.....	13
Chapter 6 - Troubleshooting.....	14
Localizing the Problem.....	14
Schematics and Parts List.....	14
Component Replacement .....	14
Block Diagram .....	15
Chapter 7 - Routine Maintenance.....	16
General.....	16
Required Test Equipment .....	16
Precision Resistors: .....	16
Test Leads: .....	16
Voltage Standard: .....	16
DMM: .....	16
Power Supply: .....	16
Calibration Procedure .....	17

VOLTAGE SENSE ADJUSTMENTS .....	17
RESISTANCE ADJUSTMENTS .....	18
FAILSAFE CHECK .....	18
LOW BATTERY & POWER-UP CHECK .....	19
Checking the Calibration Results .....	19
½ Scale and Linearity Check .....	19
Zero Check.....	19
Battery Replacement Instructions .....	19
Chapter 8 –Structural Features.....	20
Certifications .....	20
Chapter 9 - Addendums .....	21

## Table of Figures

Figure 1 - Fail-Safe test button detail (KVS) .....	7
Figure 2 - 4314KV Front Panel .....	8
Figure 3 - 4314KVS Front Panel.....	9
Figure 4 - Connection Detail .....	10
Figure 5 - Error Sources in Resistance Measurements .....	10
Figure 6 - Block Diagram .....	15
Figure 7 – Fail-Safe shorting points.....	18
Figure 8 - Pelican 1200 Case .....	20
Figure 9 - Pressure Equalization Valve.....	20

## Chapter 1 – General Information

### Instrument Description

The Valhalla Scientific Model 4314KV/KVS Digital Igniter Tester is designed to provide extremely safe and reliable resistance testing of explosive or volatile devices. Some of the proven uses include: fuses, squibs, igniters, explosive bolts, automobile airbag initiators and many others.

Essentially, a Model 4314KV/KVS is a 4-wire ohmmeter which has been designed to use very low test currents for its measurement. Additional circuitry proprietary to Valhalla Scientific is used to ensure that test current levels do not exceed the specified "failsafe current" even in a worst-case component failure situation. The failsafe feature is tested in every instrument before shipment and the results provided to the customer on a Certificate of Calibration that accompanies the unit. In addition, to prove that this level of safety is intact, the **4314KVS** is equipped with a constant test current monitoring display and a unique Fail-Safe test button that simulates a worst case component failure and displays the "real" fail-safe current, all while the output is isolated from the current source.

The Valhalla Scientific 4314KV/KVS Igniter Tester contains the enhanced inner circuitry as its ultra-safe 4314 Series predecessors, with the addition of Constant Current monitoring, Fail Safe test on the KVS model, and 7 ranges ( $2\Omega$  to  $2M\Omega$ ), all designed in a compact, rugged water resistant Pelican case for protection in the harshest environments.

Measures Under all Conditions: The 4314KV/KVS are not only the safest resistance testers for explosive devices, they are also, thanks to its case, impact resistant and water tight. The devices float in water, are water proof when closed to a depth of 3 feet, and can be operated outside in direct rain. They comes self-contained with a slim-line AC/DC Battery Charger and measurement test leads ready to use.

Standard feature of the 4314KV/KVS is a battery monitoring circuit that alerts the user if the batteries have become or will soon become unusable.

### Safety Considerations

The 4314KV/KVS Digital Igniter Testers are a battery operated equipment, for an optimal function of the Failsafe circuitry DO NOT connect the battery charger while the instrument is in an ON position. Always disconnect the battery charger before operating the instrument.

### Instrument Identification

Valhalla Scientific instruments are identified by a two part serial number. The Serial Tag is located on the rear or bottom of the instrument. The number is in a form of 66-0000. The first two digits, called the serial number prefix, indicate the model. It changes only when a change is made to the instrument. The last 4 digits, called the serial number suffix, are unique for each individual unit.

Be sure to include the entire serial number, both prefix and suffix, in any correspondence about your instrument.

The serial number can also be found on the Main Board, Calibration Tag and Certificate of Calibration.



## Chapter 2 – Unpacking and Installing

### Inspection

If the shipping carton is damaged, request that the carrier's agent be present when the unit is unpacked. If the instrument appears damaged, the carrier's agent should authorize repairs before the unit is returned to the factory. Even if the instrument appears undamaged, it may have suffered internal damage in transit that may not be evident until the unit is operated or tested to verify conformance with its specifications. If the unit fails to operate or fails to meet the performance specifications of Chapter 3, notify the carrier's agent and the nearest Valhalla Sales Office. Retain the shipping carton for the carrier's inspection. DO NOT return equipment to Valhalla Scientific or any of its sales offices prior to obtaining authorization to do so.

### Power Requirements

The Model 4314KV/KVS is powered by an internal rechargeable heavy-duty Nickel–metal hydride (NiMH) battery pack. The battery charge is maintained by an external AC/DC converter that plugs into a standard receptacle. The AC adapter can accept an input voltage from 100 to 240 Vac (50-60Hz) and an output of 6VDC @ 1.25mA.

The 4314KV/KVS must be turned off and have the adapter connected in order to charge the batteries.

The battery pack may power the 4314KV/KVS for up to 10 hours before requiring a recharge.

Although the batteries are fully charged prior to shipment, it may be desirable to refresh the charge for 24 hours before use. As a rule of thumb, the 4314KV/KVS requires twice as much time to fully recharge as the amount of discharge time. For example, if the instrument was used continuously for 2 hours, the AC adapter must be connected for 4 hours in order to fully restore the charge.

Isolated AC version are available. Option AC115.

### Installation

The Model 4314KV/KVS consumes little power and generates virtually no heat. Consequently, it may be used in any area where the environment does not exceed the temperature specifications of Chapter 3.

## Chapter 3 – Specifications

### Range/Resolution/Test Current/Failsafe Current

Table 1

Range Value	2Ω	20Ω	200Ω	2kΩ	20kΩ	200kΩ	2MΩ	Standby
Resolution	100μΩ	1mΩ	10mΩ	100mΩ	1Ω	10Ω	100Ω	-
Test Current	5mA	5mA	500μA	50μA	5μA	500nA	50nA	0A
Fail-Safe Current <sup>[1]</sup>	8mA	8mA	1.8mA	180μA	18μA	1.8μA	180nA	-

[1] Maximum value. Actual Failsafe Currents vary from instrument to instrument. The actual measured level is provided on the certificate of calibration.

### Accuracy

Table 2

Range	Accuracy
2Ω	±0.03% of reading ± 0.02% of range
20Ω	±0.03% of reading ± 0.02% of range
200Ω	±0.03% of reading ± 0.02% of range
2kΩ	±0.03% of reading ± 0.02% of range
20kΩ	±0.03% of reading ± 0.02% of range
200kΩ	±0.05% of reading ± 0.05% of range
2MΩ	±1% of reading ± 0.2% of range
<b>Current Monitor Accuracy (KVS model)</b>	
2Ω - 20kΩ	20% of displayed value
200kΩ - 2MΩ	Nominal test current value displayed

## Temperature

Temperature Coefficient:	$\pm 0.002\%$ per °C (from 0°C-15°C and 35°C-50°C) <i>not applicable for 200k<math>\Omega</math> range and above.</i>
Operating Temperature Range:	0°C to 50°C
Storage Temperature Range:	-10°C to 70°C

## General Specifications

Display Type:	4 ½ digits Light Emitting Diodes (LED) (19999)
Current Display (KVS model):	3 digits Light Emitting Diodes (LED) (999)
Overload Indication:	Screen displays "O.L."
Conversion Rate:	3 readings per second
Terminal Configuration:	4-Wire Kelvin
Current Source Compliance Voltage:	Clamped at 1.6V
Power:	(4 "D" Cell) 1.2V rechargeable NiMH Batteries 10000mAh
Battery Charger:	Provides 6VDC at 1.25A nominal

## Physical Specifications

Width:	10.62" / 27cm
Depth:	9.68" / 24.6cm
Height:	4.87" / 12.4cm
Weight:	6 lbs / 2.7kg net; 7lbs / 3.2kg shipping [2]

[2] Shipping weight may vary.

## Chapter 4 – Optional Equipment

### Available Options

Listed below are the options available for use with the 4314KV/KVS Series Digital Igniter Testers.

#### Option A2: Battery Charger

Option "A2" is an AC/DC converter 115-240VAC line voltage to 6VDC at 1.25A with locking ring, sealed IP68. One charger is provided as a standard accessory with every 4314KV/KVS.

#### Replacement Batteries

The rechargeable NiMH batteries installed in the 4314KVS should provide years of trouble-free operation. Replacement, however, will eventually be necessary. The 4314KV/KVS uses four 1.2V cells installed in a reusable battery box. When ordering replacement batteries, please specify Valhalla Stock #05-10117, quantity four (4).

#### AC-115: Continuous Isolated AC Power

Option "AC-115" allows the 4314KV/KVS to be used while plugged to the power source. Internally the source is isolated from the circuits. When this option is installed, the 4314KV/KVS is no longer battery powered. (100-240Vac 50-60Hz)

### Test Leads

#### Option K-174: 4-Wire Kelvin Lead Set (RG174 coaxial cable)

Option "K-174" comes standard with each 4314KV/KVS. Option K-174 is a shielded 48" lead set terminating in ½ inch gold plated clips. The lead set uses RG174 coaxial cable to better fit within the enclosure.

#### Option K: 4-Wire Kelvin Lead Set

Option "K" is the recommended general purpose lead set for all Valhalla Ohmmeters. Option K is a shielded 48" lead set terminating in ½ inch gold plated clips.

#### Option MP-S: Single Probe Lead Set

Option "MP-S" is a 4-wire lead set terminated in single points. The 4-wire configuration is maintained up to the point of the probe, eliminating most cable resistance effects. Option MP-S may be used where a single probe tip is a must.

#### Option MP-1: Kelvin Micro-Probes

Option "MP-1" is a 48" shielded lead set (dual banana), handheld pencil type, terminated in spring loaded steel tips with .05" separation (1 amp max.). Special orders or modified versions available upon request.

#### Option MP-2: Kelvin Mini-Probes

Option "MP- 2" is a 48" shielded lead set, handheld pencil type, terminated in spring loaded steel tips with 0.18" separation. (1 Amp max.)

#### Option MP-3: Kelvin Micro-Probes

Option "MP-3" is a 48" shielded lead set (dual banana), handheld pencil type, terminated in spring loaded steel tips with .08" separation (1 amp max.). Special orders or modified versions available upon request.

#### Option MP-4/MP-5: Surface Probes

These probes permit rapid, repeatable bonding testing on a variety of screened or flat surfaces. Test current is evenly distributed through the probe base while sensing is accomplished via a spring loaded center contact. The "MP-4" target area is 1" in diameter. The "MP-5" target area is .4" in diameter.

#### Option KK: 4-Wire Kelvin Lead Set

Option "KK" is a 48" heavy duty cable set terminated in large "jaws" that have an open span of 2".

#### Option C: Banana-to-Clip Cable

Option "C" is a 48" shielded cable terminated in dual alligator clips

#### Option BBL: Banana-to-Banana Cable

Option "BBL" is a 48" shielded cable terminated in dual banana plugs at both ends.

#### Option KCS: Kelvin Clips

Option "KCS" is the gold plated Kelvin clips used on the Option "K" cable. These clips may be used when making custom cables or when repairing Option "K".

#### Option JAWS: Heavy-Duty Clips

2" opening for use on large bushings, transformers and motors. The upper/lower jaw teeth (gold plated) provide true 4-wire measurement. Can accommodate up to 150 amps.

## Chapter 5 – Features and Operations

### General

This section of the manual contains complete operating instructions for the Model 4314KV/KVS Digital Igniter Testers. A description of the front panel controls, connection instructions, and the theory behind 4-wire resistance measurement is discussed in this section.

### Front Panel

#### ON/OFF Button

When the front panel power switch is placed in the OFF/CHARGE position, all power is removed from the output terminals, and the battery pack is connected to the charging circuit. When the switch is placed in the ON position, the battery pack is disconnected from the charging circuit. The possibility of a common mode voltage between the device under test and AC Power ground is therefore eliminated.

#### Range Selection Knob

The 4314KV/KVS measurement ranges are selected by turning the range knob to the desired position. Move knob clockwise to increase the range and counterclockwise to reduce the range. Range knob is also used to place the tester in Stand By mode.

#### Fuse Holder

The fuse holder is mounted on the front panel and contains a 2 amp in-line fuse. This fuse is designed to protect the battery pack from excessive charging currents. For continued protection, replace the line fuse only with fuse of the same voltage and current rating and type. DO NOT use repaired fuses or short-circuited fuse holders.

#### Charging Jack

The battery charging jack is a barrel type and is located on the 4314KV/KVS front panel. The center pin of the connector is positive. The charging requirements of the internal battery pack are 6VDC @ 1.25A. The correct charging voltage is supplied by the adapter included with the instrument. Additional adapters are available as Option "A2". Charger is equipped with a locking ring, and is sealed IP68.

#### Fail Safe Button (model 4314KVS only)

When pressed, the Fail-Safe test button simulates a worst case component failure and displays the “real” fail-safe current. During the test, the current source is isolated from the binding-post. The ohms measurement window will display FSt, to indicate that the unit is in fail-safe test mode.



Figure 1 - Fail-Safe test button detail (KVS)

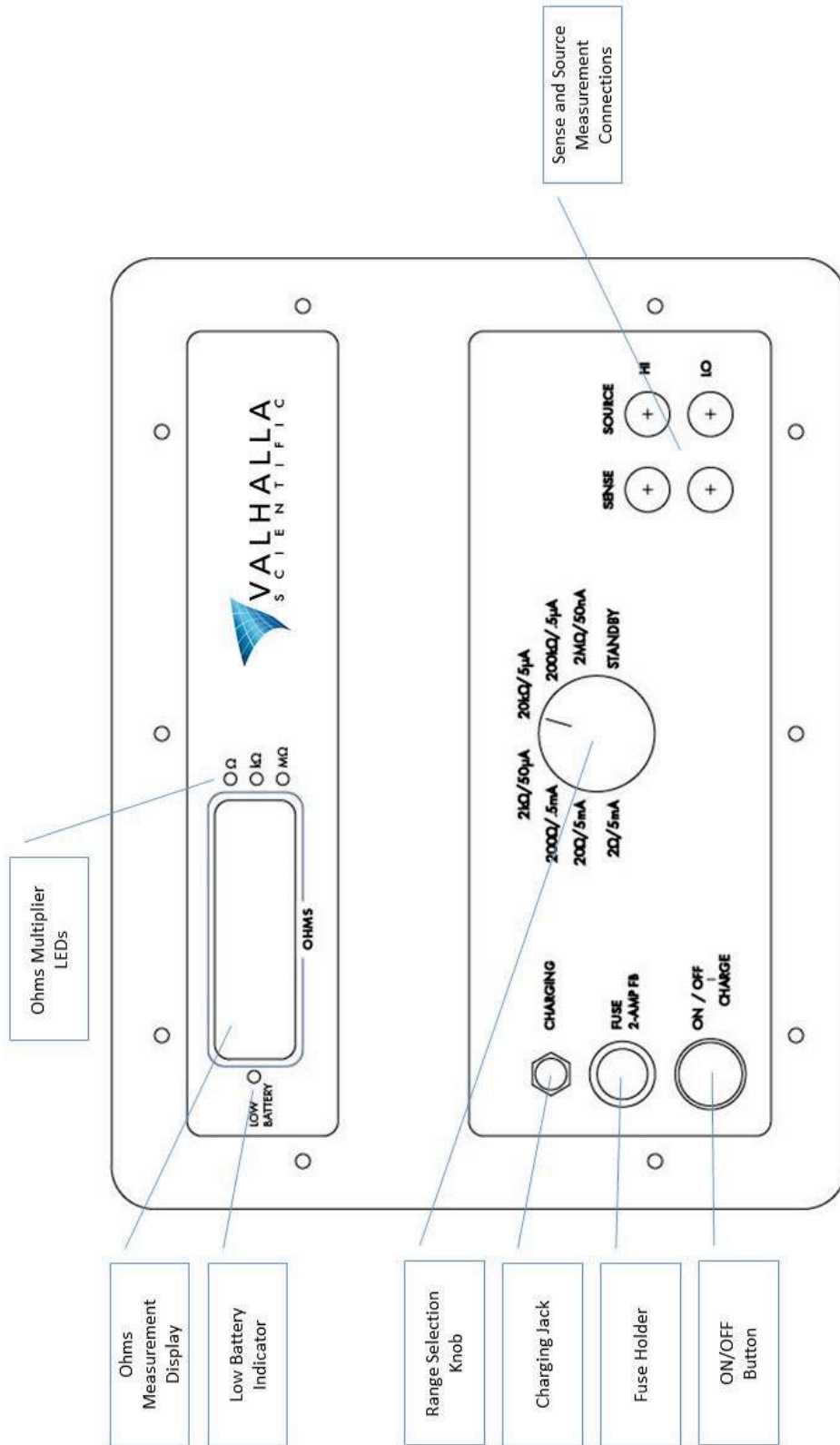

Figure 2 - 4314KV Front Panel

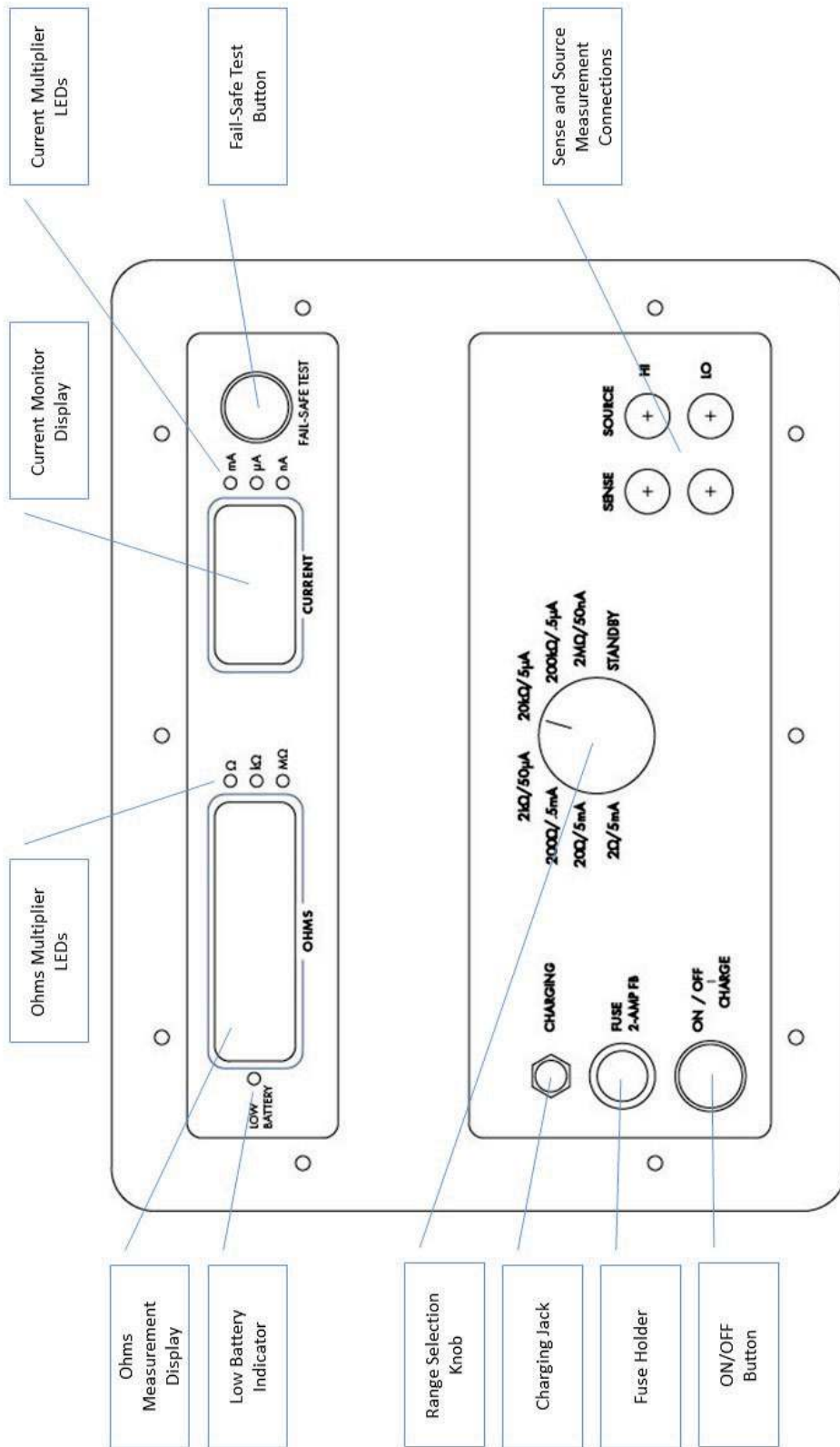

Figure 3 - 4314KVS Front Panel



## Connections

Connections are made to the front panel terminals using a 4-wire configuration as described in **4-Wire Resistance Measurement**. When using Valhalla test leads, the tabbed side of the banana jack is plugged into the current terminals. This ensures that the current is carried in the largest conductor and that the voltage input is shielded.

V<sub>HI</sub> ⚙️ ⚙️ I<sub>HI</sub> ← Tab  
V<sub>LO</sub> ⚙️ ⚙️ I<sub>LO</sub> ← Tab

## 4-Wire Resistance Measurement

The four-terminal configuration of the 4314KV/KVS eliminates errors normally caused by test lead and contact resistances. In many applications the contact resistance can exceed the value of the load by several orders of magnitude. The 4314KV/KVS bypasses this potential error source by providing two terminals of constant current and an additional two terminals for high impedance voltage measurement. The result is a fast, accurate resistance measurement of the load, independent of the resistance of the current carrying leads.



Figure 4 - Connection Detail

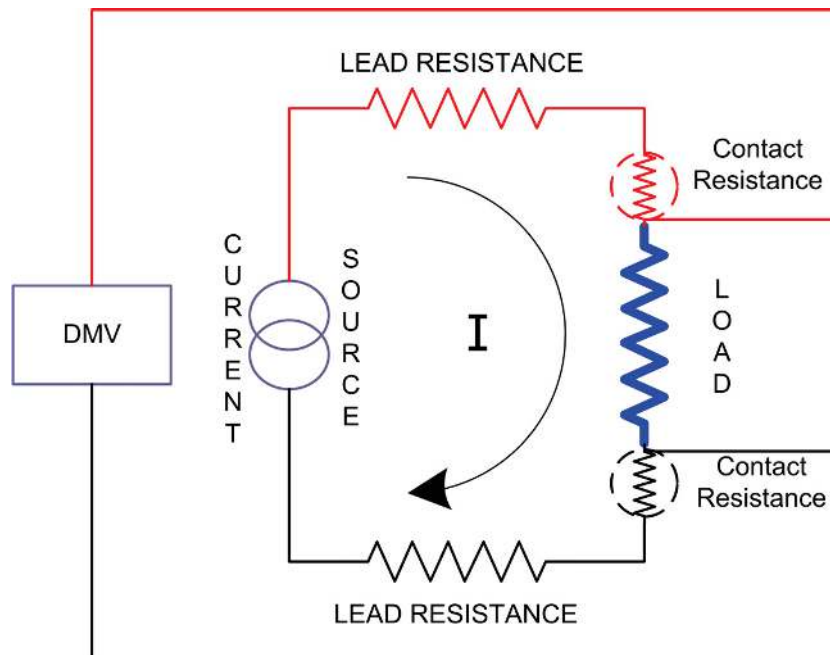

Figure 5 - Error Sources in Resistance Measurements

Figure 5 illustrates how the 4-wire principle is used to eliminate lead, wire and contact resistances as potential error sources. The internal current source inherently overcomes all series resistance (within compliance voltage limits) and delivers a precise constant current.

The internal high-impedance DVM senses the voltage drop across the load. There is negligible contact and lead resistance error created by the voltage measurement because the high input impedance of the DVM limits current flow in the voltage leads.

## Displays

### Ohms Display and Multiplier LEDs

Under normal operations, the Ohms display will indicate the value of the resistance being measured. The 3 LEDs next to the display window, will indicate whether the value displayed is in Ohms, kOhms or MOhms. (ohms, kilo-ohms or mega-ohms).

On KVS models, the ohms display will read FSt during Fail-Safe test mode.

### Interpreting the Display

All Valhalla ohmmeters and igniter testers use a high impedance voltmeter as part of the resistance measurement process. This voltmeter is a highly accurate and stable 24 bit analog-to-digital converter (ADC). Unless it is receiving a definite input signal, the output reading of this ADC is ambiguous. The display may indicate a randomly wandering number or it may indicate an over-range condition. This unpredictable display may make it seem to appear that the instrument is experiencing some sort of malfunction. It is, in fact, just a characteristic of the voltmeter circuit and should not be mistaken for a fault in the instrument.

The display indications should be ignored unless there is a definite measurement being taken. If this wandering display is not acceptable, the ohmmeter can be made to indicate zero whenever the sense terminals are shorted.

The display should indicate a stable reading when the test leads are securely attached to the device under test. If the display appears to be erroneous when connected to a load, recheck the test leads for integrity and cleanliness. If all external items appear to be functioning properly, the problem may be the ohmmeter. In this case, please contact your local Valhalla Scientific Sales Office.

### Current Display and Multiplier LEDs (KVS models only)

Under normal operations, the Current display will indicate the value of the source current being used by the tester. The 3 LEDs next to the display window, will indicate whether the value displayed is in mAmps,  $\mu$ Amps or nAmps. (milli-Amps, micro-Amps or nano-Amps). The display will indicate the measured value of the current on ranges  $2\Omega$  to  $20k\Omega$  and the nominal value of the current. The display indications should be ignored unless there is a definite measurement being taken.

When a Fail-Safe test is initiated by the user by pressing the Fail-Safe Test button, the Current display will indicate the true (measured) Fail-Safe value for the range selected.

During Fail-Safe test mode, the Current display will indicate the value of the fail-safe current being measured.

## Fail-Safe Operation

The 4314KV/KVS incorporate a proprietary current source design that renders them incapable of delivering excessive voltage or current to the device under test. Maximum Fail-Safe Current values are listed in Table 3.

Range	Fail-Safe Current[3]
2Ω	8mA
20Ω	8mA
200Ω	1.8mA
2kΩ	180μA
20kΩ	18μA
200kΩ	1.8μA
2MΩ	180nA

*Table 3 - Fail-Safe Current Values per Range*

Every 4314KV/KVS Igniter Testers are thoroughly tested before they leave the factory. These tests include a failsafe test that simulates a "worst case" failure condition. The resulting output current is recorded and provided on the Certificate of Calibration included with every unit.

### Fail-Safe Test (model 4314KVS only)

The 4314KVS is equipped with a Fail-Safe test feature that allows for real time verification of the fail-safe current. When the Fail-Safe test button is pressed, the unit disconnects the source terminals from the internal circuitry, simulates a worst case scenario failure, and measures the source current. The value measured is displayed on the Current window. If the Fail-Safe current measured ever exceeds the max values listed in Table 3, do not use the device and contact your local Valhalla Scientific Sales or Tech Support Office.

## Low Battery Indicator

A standard feature of 4314KV/KVS is a circuit that monitors the output voltage of the internal battery supply. The Battery Status LED for this feature is located to the far left of the display window.

- Non lit LED indicates that the batteries are charged and the device can be used.
- A flashing Low Battery LED, indicates that the batteries will require recharging within the next ½ hours of continuous use. Readings are still within specified accuracies at this point.
- A Red Low Battery LED indicates that battery is low and that readings should not be trusted. An overnight recharge should be performed before using the device for critical testing.

NOTE: It is possible for the user to receive a low battery indication on a single range only (particularly the 2Ω and 20Ω range), while the 4314 remains well within operating limits on other ranges. **Unless the user observes a continuous low battery indication during measurement, readings are still valid.**

## Standby Mode

Standby Mode is a safety range that allows the user to make connections to a load while there is no source current applied. The Standby range is purposely positioned as the 8<sup>th</sup> range of the 4314KV/KVS, so that they adjacent range has the lowest test current.

When in Standby mode, the 4314KV Ohms display will read StdbY. 4314KVS Ohms and Current display will read StAnd bY.

## Chapter 6 - Troubleshooting

Malfunctions are often the result of misinterpretation of specifications or due to an incomplete understanding of the instrument. **A thorough review of the operating instructions for this instrument is recommended prior to any component replacement.** Check to be sure that cables and other test equipment are in good working order before attempting to troubleshoot the 4314KV/KVS.

If the 4314KV/KVS exhibits problems that cannot be eliminated by reviewing Chapter 3 and 5, the following guidelines have been established to help solve the problem.

### Localizing the Problem

The key to successful troubleshooting is to localize the problem as much as possible before trying to pin the problem down to a specific component. Certain questions should be asked such as "Does the problem occur on all ranges or on a specific range only?" The power supplies are also one of the first things that should be checked.

### Schematics and Parts List

The schematics and parts list are not part of this User Manual. Please contact Valhalla Scientific Engineering Department for additional information.

### Component Replacement

If the problem has been identified as a faulty component, the accuracy of the 4314KV/KVS can be maintained only if the following precautions are taken:

- a) Use only the specified component or its exact equivalent. Spare parts can be ordered from your nearest Valhalla Scientific Service Center.
- b) Use only 63/37 grade rosin core electronic grade solder with a 50W or lower maximum power soldering iron.
- c) When soldering, heat the terminal of the component, not the solder. Apply solder smoothly and evenly. Do not move the component until the solder has cooled. Bad solder joints can cause additional problems!
- d) Static sensitive parts require special handling procedures. Always treat an unknown part as if it were static sensitive.

# Block Diagram

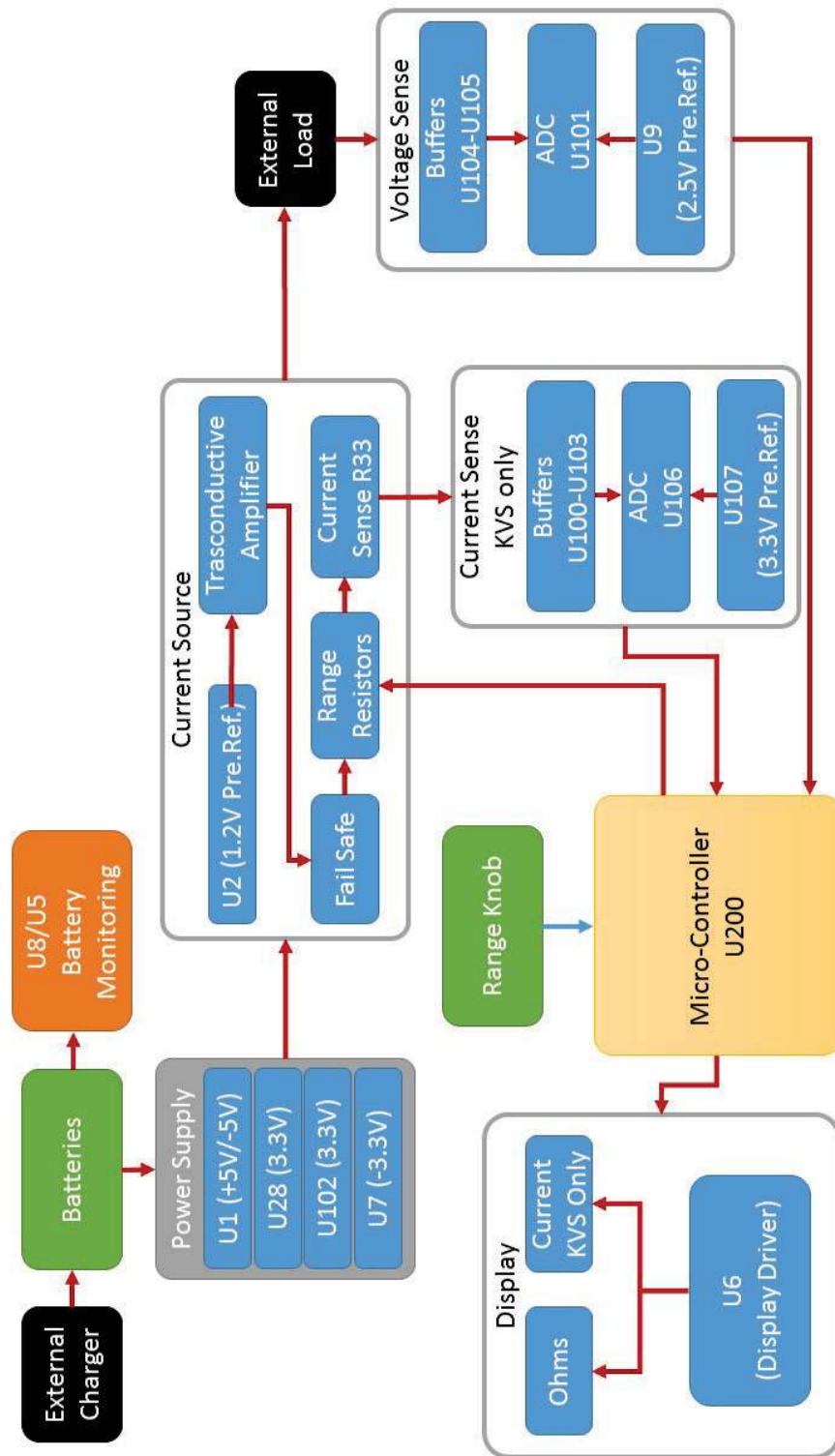

Figure 6 - Block Diagram

## Chapter 7 - Routine Maintenance

### General

This section of the manual contains routine maintenance information regarding the Valhalla Scientific Model 4314KV/KVS Digital Igniter Testers. Calibration should be performed on a regular basis to ensure continued instrument accuracy. The recommended calibration interval is 1 year.

### Required Test Equipment

Following is a list of the standard resistors and other equipment required to calibrate the 4314KV/KVS.

#### Precision Resistors:

.1 $\Omega$   $\pm$  0.01% Accuracy

1 $\Omega$   $\pm$  0.005% Accuracy

10 $\Omega$   $\pm$  0.005% Accuracy

100 $\Omega$   $\pm$  0.005% Accuracy

1K $\Omega$   $\pm$  0.005% Accuracy

10K $\Omega$   $\pm$  0.005% Accuracy

100K $\Omega$   $\pm$  0.005% Accuracy

1M $\Omega$   $\pm$  0.005% Accuracy

#### Test Leads:

4-Wire Lead Set

(Valhalla Option "K" or "C")

#### Voltage Standard:

Voltage Calibrator capable of outputting from 0V to negative 75mV, 0.03% Accuracy or better.

#### DMM:

Model 3458A or equivalent.

#### Power Supply:

Power supply capable of outputting from 4.6 to 6VDC.

## Calibration Procedure

To perform calibration, you will need access to the main board of the device. Remove the 10 panel screws to remove the panel assembly from the case.

### VOLTAGE SENSE ADJUSTMENTS

#### *Connection:*

Apply voltage at Voltage sense Input and short current source and Voltage sense negative Terminals. Using the Range Knob, select Stand By. On the main board press SW8 tact switch to initiate calibration routine.

#### *4314KV Procedure:*

1. Display will prompt "CAL-1".  
Apply 0.000mV to the Voltage Sense and press SW8.
2. When the display prompts "CAL-2".  
Apply -7.5mV and press SW8.
3. When the display prompts "CAL-3"  
Apply -75mV and press SW8.
4. Display will prompt "dOnE". Voltage Sense calibration is complete.

#### *4314KVS Procedure:*

1. Display will prompt "CAL-1".  
Apply 0.000mV to the Voltage Sense and press the FAILSAFE TEST button on the front panel.
2. When the display prompts "CAL-2".  
Apply -7.5mV and press the FAILSAFE TEST button.
3. When the display prompts "CAL-3"  
Apply -75mV and press the FAILSAFE TEST button.
4. When the display prompts "CAL-C | 5.00mA"  
Remove voltage connections and connect the Sense terminals to a 3458A precision Multimeter in DC-Amp mode.
5. Adjust RV15 for a reading of 5.00mA and press the FAILSAFE TEST button.
6. Wait for LED D200 on the main board to stop blinking. Display will remain "CAL-C | 5.00mA".
7. Adjust RV15 for a reading of 5.00mA and press the FAILSAFE TEST button.
8. When the display prompts "CAL-C | 500µA"  
Adjust RV15 for 0.500mA and press the FAILSAFE TEST button.
9. When the display prompts "CAL-C | 50.0µA"  
Adjust RV1 for 50.0µA and press the FAILSAFE TEST button.
10. When the display prompts "CAL-C | 5.00µA"  
Adjust RV2 for 5.00µA and press the FAILSAFE TEST button.
11. When the display prompts "CAL-C | 500nA"  
Adjust RV3 for 0.500µA and press the FAILSAFE TEST button.
12. When the display prompts "CAL-C | 000"  
Remove all connection from the terminals and press the FAILSAFE TEST button.
13. Display will prompt "dOnE | CAL". Voltage Sense calibration is complete.



## RESISTANCE ADJUSTMENTS

1. Select 200 $\Omega$  range.
2. Connect to a 100 $\Omega$  standard resistor.  
Adjust R15 for a display reading equal to the value of the resistor.
3. Select 2k $\Omega$  range and connect to a 1k $\Omega$  standard resistor.  
Adjust RV1 for a display reading equal to the resistor value.
4. Select 20k $\Omega$  range and connect to a 10k $\Omega$  standard resistor.  
Adjust RV2 for a display reading equal to the resistor value.
5. Select 200k $\Omega$  range and connect to a 100k $\Omega$  standard resistor.  
Adjust RV3 for a display reading equal to the resistor value.
6. Select 2M $\Omega$  range and connect to a 1M $\Omega$  standard resistor.  
No adjust. Verify that display reading is within tolerance of the resistor value.
7. Select 2 $\Omega$  range and connect to a 1 $\Omega$  standard resistor.  
No adjust. Verify that display reading is within tolerance of the resistor value.
8. If the 2 $\Omega$  range is too low select R27 using the RC Box.
9. Select 20 $\Omega$  range and connect to a 10 $\Omega$  standard resistor.  
No adjust. Verify that display reading is within tolerance of the resistor value.
10. If the 20 $\Omega$  range is too low select R37 using the RC Box.

**IMPORTANT:** If it is necessary to perform step 4.8 or 4.10, go back and forth between the 2 $\Omega$ , 20 $\Omega$  and 200 $\Omega$  ranges until all are in spec.

## FAILSAFE CHECK

1. Connect the 3458A in the ammeter mode across the current terminals. Select the 2 $\Omega$  range.
2. Short out the cathode of D9 and the bottom pin or R44 (see image) and verify that the measured current is equal or less then the value specified in the Fail Safe current table.
3. Repeat this process for each range.
4. For M $\Omega$  ranges it will be necessary to connect the appropriate calibration resistor and measure the voltage drop across it. Use Ohm's Law to calculate the failsafe current.

Range	Fail-Safe Current
2 $\Omega$	8mA
20 $\Omega$	8mA
200 $\Omega$	1.8mA
2k $\Omega$	180 $\mu$ A
20k $\Omega$	18 $\mu$ A
200k $\Omega$	1.8 $\mu$ A
2M $\Omega$	180nA



Figure 7 – Fail-Safe shorting points

## LOW BATTERY & POWER-UP CHECK

1. Remove the batteries and connect a power supply at 5.4 volts to the battery holder terminals, observing polarity.
2. Connect a  $10\Omega$  resistor in the  $20\Omega$  range. Dial the power supply down to 4.8 volts. The "Low Battery" indicator should start flashing red. Below 4.8V, "Low Battery" indicator should be solid Red. If not, adjust R32 until the LED Turn RED below 4.8V. The display **must** remain stable and must not freeze up.
3. Increase the supply to 4.81 volts and note that the LED turns off. Return the supply to 5.4 volts.
4. Turn off the power switch and remove the load. Turn the power switch back on and reconnect the load. The reading must return to the same value as before and not freeze up.
5. Remove power supply and install batteries.

## Checking the Calibration Results

### ½ Scale and Linearity Check

Apply to each range resistor values equal to 50% of range, 5% of range, 0.5% of range and 0.05% of range.

All values should be within the tolerance specified in Chapter 3.

### Zero Check

1. Apply a short between VHI and VLO.
2. Apply a short between VLO and ILO.
3. Check the display for  $0 \pm 3$  digits

## Battery Replacement Instructions

The rechargeable NiMH batteries used in the 4314KV/KVS are very durable and should provide years of trouble-free operation. As with all batteries, replacement will eventually be necessary. Batteries may be ordered from Valhalla Scientific as stock #05-10117, quantity: (4).

The process of battery replacement is described below:

Remove the 10 panel screws.

1. Undo hook and loop strap.
2. Remove the old batteries and replace. Observe polarity!
3. Secure the new batteries in place hook and loop strap.
4. Put the panel in place and tighten screws.

## Chapter 8 –Structural Features



Figure 8 - Pelican 1200 Case

- Watertight, crushproof, and dustproof
- Automatic Pressure Equalization Valve - balances interior pressure, keeps water out
- Easy open Double Throw latches

### Certifications

- Certified Mil Std 810 – Method 511 Safe for Explosive & Volatile Atmospheres
- Complies to (EWR) 127-1, Section 3.13.8.1-2
- Certified Mil Std 810 – Fungus Test
- IP67
- DEF STAN 81-41 (Vibration Test K, Impact Test E)



Figure 9 - Pressure Equalization Valve

## Chapter 9 - Addendums

Immediately following this page may be found any notices regarding manual changes, or operating considerations for special 4314KV/KVS. Please refer to any applicable material before attempting to operate your Model 4314KV/KVS

If you have a digital copy of this manual, all available addendums are stored in a folder labeled "4314KV/KVS Addendums".

Note that not all of the addendums may apply to your meter.

For questions or comments, please contact:

Valhalla Scientific, Inc.  
Engineering Department  
12127 Kirkham Rd.  
Poway California 92064

Phone: 858/457-5576  
Fax: 858/457-0127  
E-mail: [support@valhallascientific.com](mailto:support@valhallascientific.com)

For information on our line of products, please visit our web site at:

[www.valhallascientific.com](http://www.valhallascientific.com)

To reach our sales department:

Phone: 858/457-5576  
Fax: 858/457-0127  
E-mail: [sales@valhallascientific.com](mailto:sales@valhallascientific.com) or [valhalla@valhallascientific.com](mailto:valhalla@valhallascientific.com)

4314KV and 4314KVS Digital Igniter Tester User Manual  
Revision # 1 Edition 1 (2017)  
Copyright © 2017 Valhalla Scientific, Inc. All rights reserved







4314KV and 4314KVS Digital Igniter Tester User Manual  
Revision # 1 Edition 1 (2017)  
Copyright © 2017 Valhalla Scientific, Inc. All rights reserved

